

# 2017

## VOTRE PARTENAIRE POUR L'AGENCEMENT DE L'HABITAT

Your partner for home improvement  
Ihr partner für die gestaltung des  
lebensraums  
Su socio para el acondicionamiento  
de la vivienda



 **NORDLINGER  
PRO**

[www.nordlinger-pro.com](http://www.nordlinger-pro.com)     

# NORDLINGER PRO

Plus de 80 ans d'expérience ont permis  
à la société Nordlinger Pro de devenir leader  
dans le domaine des bandes de chants  
et des solutions d'amélioration de l'habitat.



## Vos administratrices des ventes

Export : Christine  
+ 33 5 45 78 79 57



Christine  
05 45 78 79 57

14/16/17/18/22/23/27/  
28/29/35/36/37/41/44/  
45/49/50/52/53/56/61/  
72/76/79/85/86/95



Gaëlle  
05 45 78 79 71

01/03/04/05/07/08/10/  
21/25/26/38/39/42/43/  
51/52/54/57/58/63/67/  
68/69/70/71/73/74/84/  
88/89/90



Marie  
05 45 78 33 04

06/09/11/12/13//15/19/20/24/30/31/  
32/33/34/40/46/47/48/64/65/66/81/  
82/83/87/02/59/60/62/75/77/78/80/  
91/92/93/94/95/ANDORRE/MONACO

- Barrières de sécurité enfants
- Barrières de lit
- Accessoires de sécurité domestique

## SÉCURITÉ p 36



## PANNEAUX p 6

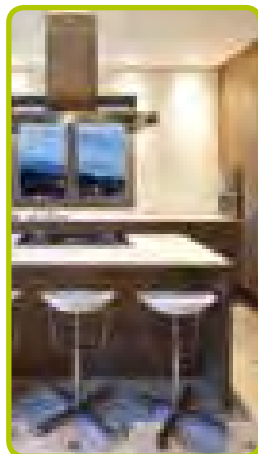
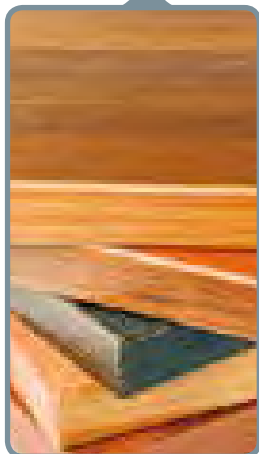

## CUISINE p 18

- Profilés pour crédence et plan de travail
- Étanchéité de crédence et plan de travail
- Accessoires pour plinthes
- Accessoires pour meubles de cuisine



## ACCESSOIRES & OUTILLAGE p 29

- Systèmes d'assemblage
- Cannage
- Anti-dérappant lattes & embouts
- Tréteaux
- Fermetures extensibles pour animaux



## AIDES À LA VENTE p 41

## CONDITIONS GÉNÉRALES DE VENTE p 43



## SOL & MUR p 26

- Cales pour parquet
- Plinthes cache'fil
- Clips à lambris et accessoires

Les dimensions figurant dans ce catalogue sont indicatives et peuvent accepter de légères variations. Documents et photographies non contractuels.

The dimensions stated in this catalogue are for information only and are subject to slight variations. Documents and photographs are not contractual. Die Abmessungen in diesem Katalog sind unverbindlich und können geringfügige Abweichungen zu akzeptieren. Dokumente und Fotos sind nicht vertraglich. Las dimensiones de este catálogo son indicativas y pueden aceptar ligeras variaciones. Documentos y fotografías no contractuales

Pour tous les produits : Gencod = 3 35476 XXXXXX X (ref pdt)

- H.** Hauteur  
Height • Höhe • Altura
- l.** Largeur  
Width • Breite • Ancho
- L.** Longueur  
Length • Länge • Longitud
- Ep.** Épaisseur  
Thickness • Dicke • Espesor
- UC.** Unité de commande  
Order unit • Bestelleinheit  
Unidad de pedido



**Sachet cavalier** Plastic bag with header • Plastikbeutel mit Header  
Bolsa de plástico con cabecera



**Skin-pack**  
Skin Pack • Skin Pack • Skin Pack



**Boite**  
Box • Box • Caja



**Fourreau**  
Sleeve • Schlauch • Tubo



**Rouleau**  
Roll • Rolle • Rollo



**Chant : film plastique** Plastic film  
Plastiktasche • Bolsa de plástico



**Chant : vrac** Bulk  
Unverpackt • A granel



**Barrière : film plastique** Plastic film  
Plastiktasche • Bolsa de plástico

## CONCEPTION

Une équipe « Recherche & Développement » de 5 personnes pour concevoir et mettre au point des solutions techniques innovantes, pour gagner en performance et faciliter la mise en œuvre.

A 5 person R & D team to design and develop innovative and technical solutions to improve performance and make implementation easier • Ein R & D Team von 5 Personen, das innovative technische Lösungen entwirft und entwickelt, um sie effizient und einfach zu implementieren • Un equipo de I + D de 5 personas para diseñar y desarrollar soluciones técnicas innovadoras para mejorar el rendimiento y facilitar su aplicación.



## FABRICATION



Une parfaite maîtrise de la chaîne de fabrication grâce à une expertise industrielle de 60 ans.

Perfect control of the production line thanks to an industrial expertise of more than 60 years • Eine perfekt kontrollierte Produktionslinie dank eines industriellen Know-hows von mehr als 60 Jahren • Perfecto control de la línea de producción gracias a una experiencia industrial de más de 60 años.

## MARKETING



Une approche marketing au service de votre stratégie :

- des gammes efficaces vous garantissant une couverture optimale de vos marchés,
- des services et des outils d'aide à la vente dédiés pour dynamiser vos ventes,
- une compétitivité de tous les instants.

A marketing approach to serve your strategy : effective ranges guaranteeing optimal coverage of your markets - dedicated services to boost your sales - competitiveness at all times • Ein Marketing-Ansatz, um Ihre Strategie zu unterstützen: effektive Kollektionen, die eine optimale Abdeckung Ihrer Märkte garantieren - spezielle Dienstleistungen, um Ihren Umsatz zu steigern - Wettbewerbsfähigkeit zu jeder Zeit • Un enfoque de marketing al servicio de su estrategia: colecciones eficaces para garantizar una cobertura óptima de sus mercados - servicios dedicados para aumentar sus ventas - competitividad en todo momento.

## À VOTRE ÉCOUTE

Une organisation commerciale de 11 personnes à l'écoute de vos besoins et à vos côtés pour accélérer votre développement.

A commercial team of 11 people listening to your needs and by your side to accelerate your development • Ein kommerzielles Team von 11 Personen hört auf Ihre Bedürfnisse und beschleunigt an Ihrer Seite Ihre Entwicklung • Una organización comercial de 11 personas escuchando sus necesidades y a su lado para acelerar su desarrollo.



## NORMES



Nos produits sont conçus, fabriqués et contrôlés dans un total respect des normes et exigences en vigueur selon un cahier des charges très strict répondant aux exigences des professionnels.

Our products are designed, manufactured and tested in full compliance with current standards according to strict specifications that meet the requirements of the trade • Unsere Produkte sind in voller Übereinstimmung mit den geltenden Normen entwickelt, gefertigt und geprüft, und unterliegen strengen Vorgaben, die den Anforderungen von Profis entsprechen • Nuestros productos están diseñados, fabricados y probados en plena conformidad con las normas vigentes y conforme a normativas estrictas que cumplan los requisitos de los profesionales.

## LOGISTIQUE



Une logistique dédiée à nos clients dont l'excellence est reconnue depuis plus de 30 ans.

Dedicated logistics to customers whose excellence has been recognized for over 30 years • Spezielle Kundenlogistik, deren Exzellenz seit über 30 Jahren anerkannt ist • Logística dedicada a los clientes cuya excelencia ha sido reconocida por más de 30 años.

NOUVEAU

# BY One

Les couleurs du négoce

## GAMME CHANTS PLASTIQUES NON ENCOLLÉS

- ✓ Des concordances parfaites avec les plus grandes marques de panneaux.
- ✓ Consultez le module de recherche en ligne, simple, rapide et accessible à tout moment.

PFLIEDERER FORMICA POLYREY WODEGO  
FINSA KRONO RESOPAL  
EGGER KRONOSWISS RESOPAL KRONOSPAN  
WODECO RESOPAL KRONOFRANCE THERMOPAL FINSA  
RESOPAL UNILIN FORMICA



Votre bande de chant à partir de 1 mètre linéaire.



Bandes de chant disponibles en différentes épaisseurs (0.45 mm, 1 mm, 2 mm).



Une gamme complète, composée de 1000 décors au choix.



Différentes largeurs sont proposées, jusqu'à 66 mm.



Prestation découpe possible.



Prestation encollage possible sur simple demande.



Option Airtech et Lasertech sur demande, avec délai supplémentaire.



Tarif unique livraison.

## 1000 DÉCORS AU CHOIX, LA FLEXIBILITÉ EN PLUS !

Offres quantitatives



Nuancier décors sur demande



Module de recherche de concordances en ligne



<http://finder.nordlinger.pro.com>



# Bandes de chant mélaminées

Melamine edgings  
Melamin Kantenumkleimer  
Cantos Melamínicos



Ep. ± 0,3 mm

**Non Encollé  
(Mélanor)**  
non pre-glued  
ohne  
Schmelzkleber  
sin cola

**Pré Encollé  
(Mélafix)**  
pre-glued • mit Schmelzkleber  
con cola

**Auto-Adhésif  
(Méladhésif)**  
self-adhesive  
selbstklebend • autoadhesivo

<b>L.</b>	<b>23 mm</b>	<b>23 mm</b>				<b>16 mm</b>		<b>19 mm</b>			
<b>L.</b>	<b>100 ml</b>	<b>5 ml</b>	<b>25 ml</b>	<b>50 ml</b>	<b>100 ml</b>	<b>5 ml</b>	<b>25 ml</b>	<b>5 ml</b>	<b>25 ml</b>		

Type	Code	Décor	Surface	Ref Pdt								
Brut	S 83	Beige Beige		141001 9	151001 6	151003 0	-	-	-	-	-	-
Blanc	L 001	Blanc à laquer White • weiss • blanco	L	061019 9	071023 3	074061 2	-	-	-	-	-	-
	P 099	Blanc White • weiss • blanco	L	061323 7	071029 5	074066 7	075457 2	075462 6	160007 6	160023 6	160001 4	160013 7
	P 099		G	061472 2	071257 2	074069 8	075493 0	075461 9	-	-	-	-
	P 150		L	061427 2	071024 0	074062 9	075513 5	075468 8	-	-	-	-
	P 150	G	061476 0	071306 7	074293 7	075590 6	075492 3	-	-	-	-	-
	P 268	Blanc brillant White • weiss • blanco	VB	060205 7	071025 7	074063 6	-	-	-	-	-	-
	S 5022	Blanc très brillant White • weiss • blanco	VTB	060218 7	070692 2	070694 6	-	070700 4	-	-	-	-
P 099	Blanc pores frêne Ash • esche • fresno	PF	060092 3	071691 4	074390 3	075821 1	071620 4	-	-	-	-	
Beige	P 119 ☒	Beige clair Beige	G	060119 7	074208 1	074072 8	074505 1	070359 4	-	-	-	-
	P 104 ☒	Seringa Syringa • seringa	L	061671 9	071026 4	074064 3	070113 2	075725 2	-	-	-	-
	P 104 ☒	Seringa Syringa • seringa	G	061598 9	071328 9	074224 1	075658 3	075744 3	-	-	-	-
Brun	S 0845	Brun taupe / Moka Moka	L	-	070516 1	-	-	-	-	-	-	-
	S 5182	Taupe L2201 Mole • Maulwurf • Topo	L	-	121829 5	-	-	-	-	-	-	-
Rouge	I 267 ☒	Rouge Red • rot • rojo	L	061651 1	071228 2	074338 5	075699 6	070366 2	-	-	-	-
	I 474 ☒	Rouge Red • rot • rojo	G	-	-	-	-	-	-	-	160106 6	-
Orange	I 446 ☒	Orange Orange • Orange • Naranja	G	-	-	-	-	-	-	-	160108 0	-
Vert	W 1600 ☒	Vert 285 U Green • Grün • Verde	L	-	070514 7	-	-	-	-	-	-	-
	I 491	Vert reinette Light Green • Grün • Verde claro	L	-	-	-	-	-	-	-	160109 7	-
Gris	P 121	Gris clair / Béton clair Grey • grau • gris	L	061560 6	071027 1	074065 0	070301 3	070361 7	-	-	160102 8 ☒	160131 8 ☒
	P 121	Gris clair / Béton clair Grey • grau • gris	G	061584 2	074446 7	074347 7	075657 6	075781 8	-	-	-	-
	I 296	Gris n°1 / Anthracite Grey • grau • gris	G	060060 2	070796 7	074408 5	075839 6	070367 9	-	-	160174 5	-
Noir	I 264	Noir Black • Schwarz • Negro	L	061582 8	071030 1	074076 6	071802 4	075546 3	160008 3	160019 9	160002 1	160016 8
	I 264	Noir Black • Schwarz • Negro	G	061474 6	071220 6	074283 8	075690 3	075534 0	-	-	-	-
	S 5021	Noir très brillant Black • Schwarz • Negro	VTB	060216 3	070693 9	070695 3	-	070698 4	-	-	-	-
	W 629 ☒	Noir pores frêne Black • Schwarz • Negro	PF	061553 8	071244 2	071247 3	075719 1	070357 0	-	-	-	-
Métal Minéral	I 442	Gris alu Alu		060131 9	070232 0	070451 5	070334 1	070375 4	160098 4	-	160113 4	-
	F 5000	Béton Concrete • Beton • Hormigón		-	070697 7	-	-	070743 1	-	-	-	-
	S 5140	Béton gris usé / Brossé Concrete • Beton • Hormigón		-	121749 6	-	-	-	-	-	-	-
	S 5138	Béton minéral / Griffé / OxiD 37 Concrete • Beton • Hormigón		-	121814 1	-	-	-	-	-	-	-
	S 5183	Béton clair SB Concrete • Beton • Hormigón		-	121828 8	-	-	-	-	-	-	-
	F 5020	Béton brossé	<b>NOUVEAU</b>	-	-	-	-	-	-	-	-	160181 3
Bois gris	W5010	Urban Urban		-	070752 3	-	-	-	-	-	-	-
	W 1857	Chêne grisé 860 Oak • Eiche • Roble		-	070669 4	070679 3	-	-	-	-	160138 7	-
	W 5011	Chêne soûlé 868 Oak • Eiche • Roble		-	070753 0	-	-	-	-	-	-	-
	S 5184	Gris agadir tissé F755 Grey • Grau • Gris		-	121830 1	-	-	-	-	-	-	-
	S 0804	Pin nouveau grisé Pine grey • Grün • Pino gris		-	121812 7	-	-	-	-	-	-	-
Bois clair	F 429 ☒	Multiplis Multiplis	L	-	-	-	-	-	-	-	160114 1	160154 7
	W 1856	Frêne / Pin blanchi White pine • Kiefer • Pino blanco		060212 5	070670 0	070677 9	071446 0	070734 9	-	-	160139 4	160157 8
	W 1597	Planche blanc usé / Chêne blanchi antique		-	070802 5	070681 6	-	-	-	-	-	-
	W 5003 ☒	Chêne cérusé blanchi Oak • Eiche • Roble		-	070691 5	070720 2	-	-	-	-	-	-
	W 1421	Bouleau / Érable Maple • Ahorn • Arce		061770 9	071400 2	074708 6	071816 1	070347 1	160020 5	-	160046 5	-
	W 5012	Acacia crème Ash • Esche • Fresno		-	070758 5	-	-	-	-	-	-	-
	W 5001 ☒	Chêne clair blanc Oak • Eiche • Roble		-	071821 5	070682 3	-	-	-	-	-	-
	W 706	Hêtre flamme / Érable Maple • Ahorn • Arce		060129 6	070417 1	070420 1	070322 8	070373 0	-	-	-	-
	W 316	Chêne naturel / nouveau SB / Blanc 327 U Oak • Eiche • Roble		060130 2	070234 4	070419 5	070321 1	070374 7	160009 0	-	160003 8	160031 1



**Non Encollé  
(Mélanor)**  
non pre-glued  
ohne  
Schmelzkleber  
sin cola

**Pré Encollé  
(Mélatif)**  
pre-glued • mit Schmelzkleber  
con cola

**Auto-Adhésif  
(Méladhésif)**  
self-adhesive  
selbstklebend  
autoadhesivo

<b>e.</b>	<b>23 mm</b>	<b>23 mm</b>				<b>16 mm</b>	<b>19 mm</b>
<b>L.</b>	<b>100 ml</b>	<b>5 ml</b>	<b>25 ml</b>	<b>50 ml</b>	<b>100 ml</b>	<b>5 ml</b>	<b>25 ml</b>

Type	Code	Décor	Surface	Ref Pdt							
Bois clair	W 1634	Chêne nat clair 387 Oak • Eiche • Roble	-	070539 0	070678 6	-	070745 5	160175 2	-	160140 0	-
	W 1635	Chêne grenade / Canada / Acacia tabac Oak • Eiche • Roble	-	070540 6	070684 7	-	-	-	-	-	-
	W 602	Pin Pine • Kiefer • Pino	061606 1	071049 3	074098 8	075659 0	075740 5	160011 3	160130 1	160005 2	160033 5
	W 937	Hêtre Loire / 747 Beech • Buche • Haya	061676 4	071397 5	074694 2	071815 4	071492 7	160015 1	-	160014 4	160022 9
	W 080	Hêtre clair du jura Beech • Buche • Haya	060115 9	070033 3	071868 0	070100 2	070350 1	-	-	-	-
	W 522	Hêtre Beech • Buche • Haya	061603 0	071278 7	074292 0	075672 9	075785 6	160101 1	-	160100 4	-
	W 495	Pommier Apple-tree • Apfelbaum • Manzano	060066 4 *	070186 6 *	070185 9 *	070148 4 *	070372 3 *	160067 0 *	160085 4 *	160068 7	160088 5
	S 5037	Chêne du Québec / Dakota Oak • Eiche • Roble	-	121588 1	-	-	-	-	-	-	-
Bois brun	W 5018 *	Chêne modé Oak • Eiche • Roble	-	-	-	-	-	160143 1	-	-	-
	W 897	Noyer trois Walnut • Nussbaum • Nogal	061612 2 *	071343 2 *	074552 5 *	071813 0 *	070346 4 *	-	-	160144 8	-
	W 108	Chêne naturel Oak • Eiche • Roble	060108 1	070403 4	074688 1	071842 0	071687 7	-	-	-	-
	W 542	Chêne clair Oak • Eiche • Roble	061663 4	071044 8	074094 0	071812 3	075685 9	-	-	160176 9	-
	W 593	Chêne lamellé Oak • Eiche • Roble	060068 8	071054 7	074170 1	070084 5	070342 6	-	-	-	-
	W 933 *	Teck / Pin olvéga / Chêne Hélène Teck • Teak • Teca	061788 4	071801 7	071717 1	071741 6	071803 1	-	-	-	-
	W 211 *	Chêne clair sully Oak • Eiche • Roble	060055 8	070197 2	070193 4	070170 5	070175 0	-	-	-	-
	W 1615 *	Chêne hélène Oak • Eiche • Roble	-	070530 7	070680 9	-	-	-	-	-	-
	S 5107	Chêne authentique / Gris / H443 Colorado Oak • Eiche • Roble	-	121701 4	-	-	-	-	-	-	-
	S 5133	Chêne Bodega Oak • Eiche • Roble	-	121748 9	-	-	-	-	-	-	-
S 5181	Chêne tissé marron Oak • Eiche • Roble	-	121827 1	-	-	-	-	-	-	-	
Bois rouge	W 865 *	Merisier moyen Cherry • Kirsche • Cerezo	060112 8	071370 8	074658 4	071810 9	070220 7	-	-	-	-
	W 020	Merisier/Prunier foncé SB Cherry • Kirsche • Cerezo	060072 5	070057 9	071867 3	070099 9	070349 4	160012 0	-	160006 9	160021 2
	W 1637 *	Teck miel Teck • Teak • Teca	-	070536 9	070688 5	-	070736 3	-	-	-	-
	W 013	Acajou Mahogany • Mahogany • Caoba	060069 5	071874 1	071723 2	071744 7	070338 9	160048 9	-	160044 1	160126 4
Bois rustique	W 992	Vieux chêne Oak • Eiche • Roble	060054 1	070189 7	070267 2	070169 9	070174 3	-	-	-	-
	W 561 *	Chêne dauphine Oak • Eiche • Roble	061605 4	071226 8	074104 6	074508 2	075463 3	-	-	-	-
	W 611 *	Chêne des vosges Oak • Eiche • Roble	061697 9 *	071128 5 *	074109 1 *	070013 5 *	075485 5 *	160010 6	-	160004 5	160032 8
	W 5005 *	Noyer clair Walnut • Nussbaum • Nogal	-	070708 0	070733 2	-	-	-	-	-	-
	W 014 *	Noyer Walnut • Nussbaum • Nogal	-	070801 8	-	-	-	-	-	160103 5	-
Bois foncé	W 1411	Noyer américain Walnut • Nussbaum • Nogal	-	070491 1	-	-	-	-	-	-	-
	W 1638 *	Teck cognac Teck • Teak • Teca	-	070537 6	070687 8	-	-	-	-	160142 4	-
	W 1427 *	Makassar Makassar	-	070535 2	070685 4	-	-	-	-	-	-
	W 5000 *	Pin ottawa Pine • Kiefer • Pino	-	070671 7	070686 1	-	-	-	-	-	-
	W 1855	Chêne anthracite foncé wengé Oak • Eiche • Roble	-	070668 7	070683 0	-	-	-	-	-	-
		Planche noir usé Oak • Eiche • Roble	-	070799 8	-	-	-	160148 6 *	-	160137 0	-
	W 1572	Wengé / Noyer foncé Wengé	060132 6	070233 7	070270 2	070263 4	070376 1	160086 1	160104 2	160087 9	160127 1
	W 5013	Chêne foncé 436 Oak • Eiche • Roble	-	070794 3	-	-	-	-	-	-	-
	S 5172	Wengé Wengé	-	121798 4	-	-	-	-	-	-	-

**L** : Lisse Smooth • Glatte Oberfläche • Superficie lisa / **G** : Grainé Embossed • Perl Struktur • Poro soft  
**PF** : Pores frêne Ash embossing • Dekor Esche • Relieve fresno / **VB** : Verni brillant Glossy varnish • Glanzlack • Barniz brillo  
**VTB** : Verni très brillant High gloss varnish • Hochglanz-Lack • Barniz con mucho brillo  
 \* Jusqu'à épuisement du stock



## Bandes de chant mélaminées > largeurs spéciales

Melamine edgings >  
Special widths  
Melamin Kantenumleimer >  
Spezielle Breiten  
Cantos Melamínicos >  
Anchos especiales



Ep. ± 0,3 mm



L.

Non Encollé  
(Mélanor)

non pre-glued  
ohne Schmelzkleber  
sin cola

Pré Encollé  
(Mélafix)

pre-glued • mit Schmelzklebe • con cola



100 ml



1,32 ml

4,20 ml

5 ml

25 ml

100 ml

ℓ.	Type	Code	Décor	Surface	Ref Pdt							
					100 ml		1,32 ml	4,20 ml	5 ml	25 ml	100 ml	
20 mm	Blanc	P 099	Blanc White • weiss • blanco	L	061594 1	061003 8	-	-	071190 2	074193 0	075664 4	075012 3
		P 099		G	-	060105 0	-	-	070041 8	074287 6	-	075234 9
		P 150		L	-	061002 1	-	-	071004 2	074008 7	-	075013 0
		P 150		G	-	060136 4	-	-	-	070027 2	-	-
26 mm	Blanc	P 099	Blanc White • weiss • blanco	L	060076 3	061167 7	-	-	-	070423 2	070303 7	070035 7
		P 099		G	060093 0	061190 5	-	-	-	-	-	071547 4
		P 150		L	061564 4	061672 2	-	-	-	-	-	070238 2
		P 150		G	061785 3	060010 7	-	-	-	-	-	070217 7
34 mm	Blanc	P 099	Blanc / Super White • weiss • blanco	L	-	-	-	-	070797 4	-	-	-
	Brun	W 1601	Brun taupe Moka Moka	G	-	-	-	-	070750 9	-	-	-
		S 5107	Chêne authentique / Gris / H443 Colorado Oak • Eiche • Roble		-	-	-	-	121811 0	-	-	-
	Gris	P 121	Gris clair / Béton clair Grey • Grau • Gris	L	-	060232 3	-	-	070749 3	-	-	-
	Métal/Minéral	S 5138	Béton minéral / Griffé / Oxid 37 Concrete • Beton • Hormigon		-	-	-	-	121815 8	-	-	-
	Bois gris	S 0804	Pin nouveaux grisé Pine grey • Grün • Pino gris		-	-	-	-	121813 4	-	-	-
	Bois clair	W 1597	Planche blanc usé / Ch blanchi / Antique Oak • Eiche • Roble		-	-	-	-	070798 1	-	-	-
		W 1634	Chêne nat clair 387 Oak • Eiche • Roble		-	-	-	-	070748 6	-	-	-
Bois foncé	W 1855	Planche noir usé / Chêne anthracite / Foncé Oak • Eiche • Roble		-	-	-	-	070800 1	-	-	-	
38 mm	Blanc	S 5022	Blanc très Brillant White • weiss • blanco	VTB	-	-	-	-	070710 3	-	-	-
	Noir	S 5021	Noir très brillant Black • Schwarz • Negro	VTB	-	-	-	-	070709 7	-	-	-
42 mm	Blanc	P 099	Blanc White • weiss • blanco	L	061575 0	061084 7	-	-	071172 8	074138 1	075653 8	075128 1
		P 099		G	-	061312 1	-	-	074550 1	074240 1	-	075447 3
		P 150		L	061566 8	061055 7	-	-	071093 6	074134 3	071473 6	075096 3
		P 150		G	-	065716 3	-	-	070020 3	075529 6	-	075203 5
		S 0840			Blanco White • Weiss • Blanco		-	-	121831 8	121832 5	-	-
	Beige	P 104	Seringa Syringa • Seringa	L	-	061782 2	-	-	071095 0	074136 7	-	075097 0
	Noir	I 264	Noir Black • Schwarz • Negro	L	060161 6	061263 6	-	-	071096 7	074139 8	-	075099 4
	Métal Minéral	I 442	Gris alu alu		-	060204 0	-	-	070523 9	070643 4	-	070723 3
		S 5140	Béton / Basalt Concrete • Beton • Hormigon		-	-	-	-	121809 7	-	-	-
		S 5147	Ciment Cement • Mörtel • Cemento		-	-	-	-	121835 6	121836 3	-	-
		S 5145	Ardoise Slate • Schiefer • Pizarra		-	-	-	-	121837 0	121838 7	-	-
		F 408	Gris moucheté Grey marble • Grau • Gris		-	-	070804 9	070803 2	-	-	-	-
	Bois clair	W 1421	Bouleau / Érable Maple • Ahorn • Arce		-	060104 3	-	-	070204 7	070292 4	-	-
		W 937	Hêtre Loire / 747 Beech • Buche • Haya		-	060159 3	-	-	070144 6	070299 3	-	070243 6
		W 522	Hêtre Beech • Buche • Haya		-	060080 0	-	-	070143 9	070427 0	-	070227 6
		W 495	Pommier Apple-tree • Apfelbaum • Manzano		-	-	-	-	070146 0	070507 9	-	-
	Bois brun	W 593	Chêne lamellé Oak • Eiche • Roble		-	-	-	-	070202 3	070241 2	-	070522 2
		S 5131	Lamello Oak • Eiche • Roble		-	-	121833 2	121834 9	-	-	-	-
Bois rouge	W 020	Merisier / Prunier foncé SB Cherry • Kirsche • Cerezo		-	060197 5	-	-	070203 0	070424 9	-	-	
Bois rustique	W 1165	Noyer K Walnut • Nussbaum • Nogal		-	-	-	-	070526 0	-	-	-	
Bois foncé	W 1572	Wengé / Noyer foncé Wenge		-	-	-	-	070524 6	070642 7	-	070655 7	
Bois gris	S 0804	Pin nouveaux grisé Pine grey • Grün • Pino gris		-	-	121840 0	121839 4	-	-	-	-	





## Bandes de chant bois véritable

Natural wood veneer edgings • Echtholz Furnier  
Kanten • Cantos de chapa de madera

Chant bois sur  
support non tissé



	Non Encollé (Rolchant) non pre-glued ohne Schmelzkleber • sin cola	Pré Encollé (Rolfix) pre-glued • mit Schmelzkleber • con cola			Non Encollé Épais (Alèse Bois) non pre-glued • ohne Schmelzkleber sin cola	
<b>Ep.</b>	+/- 0,6 mm	+/- 0,6 mm			+/- 2 mm	+/- 3 mm
<b>ℓ.</b>	23 mm	23 mm	40 mm	23 mm	24 mm	
<b>L.</b>	100 ml	100 ml	20 ml	5 ml	50 ml	

Essence	Ref Pdt						
Chêne Oak • Eiche • Roble	290502 6	260103 4	260503 2	260517 9	220702 1	250412 0	250142 6
Acajou Mahogany • Mahagoni • Caoba	290505 7	260100 3	260500 1	260507 0	220700 7	250000 9	-
Aniégéré Anigre • Anegre • Mukaly	290506 4	260101 0	260541 4	-	220701 4	-	-
Châtaignier Chestnut-tree • Kastagnie • Castaño	290518 7	260102 7	260601 5	-	220029 9	-	-
Érable Maple • Ahorn • Arce	290314 5	260697 8	260708 1	-	220030 5	250039 9	-
Frêne Ash • Esche • Fresno	290500 2	260105 8	260504 9	260538 4	220703 8	250413 7	-
Hêtre Beech • Buche • Haya	290507 1	260106 5	260506 3	260539 1	220704 5	250298 0	-
Hêtre étuvé Beech • Buche • Haya	290000 7	260009 9	260013 6	-	220037 4	250327 7	-
Koto	290514 9	260107 2	260518 6	-	220705 2	-	-
Merisier Cherry • Kirsche • Cerezo	290504 0	260110 2	260523 0	260024 2	220707 6	250465 6	-
Noyer Walnut • Nussbaum • Nogal	290508 8	260111 9	260524 7	-	220708 3	250041 2	-
Okoumé Okoume • Okume	290510 1	260112 6	260519 3	260021 1	220710 6	-	-
Orme Elm • Ulme • Olmo	-	260113 3	260520 9	-	220709 0	-	-
Pin Pine • Kiefer • Pino	290503 3	260114 0	260505 6	260569 8	220711 3	250466 3	-
Poirier Pear • Birnbaum • Peral	290056 4	290094 6	290069 4	-	-	-	-
Sapin Fir-tree • Tanne • Pino	290554 5	260143 0	260537 7	-	220815 8	-	-
Teck Teak • Teca	290517 0	260116 4	260521 6	260030 3	220714 4	250040 5	-
Wengé Wenge	290057 1	290073 1	290043 3	260059 4	-	-	-

## Bandes de chant plastique NORDEX

Plastic Edgings • Plastische-Kantenumleimer • Cantos plásticos

Existe aussi en  
Pré Encollé

	Non Encollé (Nordex) non pre-glued • ohne Schmelzkleber • sin cola										
<b>Ep.</b>	2 mm	0,8 mm	0,6 mm	0,45 mm	0,8 mm	0,6 mm	0,8 mm	2 mm	0,8 mm	0,8 mm	
<b>ℓ.</b>	23 mm				16 mm		26 mm		33 mm		45 mm
<b>L.</b>	100 ml										

Décor	n° décors	Surface	Ref Pdt									
Blanc White • weiss • blanco	0 13265	L	011563 2	010052 2	011415 4	011406 2	010176 5	010109 3	010117 8	011605 9	010241 0	010243 4
	0 13265	G	011635 6	010053 9	011444 4	011286 0	-	010108 6	010118 5	010021 8	010242 7	010244 1

L : Lisse Smooth • Glatte Oberfläche • Superficie lisa / G : Grainé Embossed • Perl Struktur • Poro soft

VB : Verni brillant Glossy varnish • Glanzlack • Barniz brillo / VTB : Verni très brillant High gloss varnish • Hochglanz-Lack • Barniz con mucho brillo

\* Jusqu'à épuisement du stock

⊗ Disponible en 40 mm Available in 40 mm • Auch in 40 mm • Disponible en 40 mm



## Bandes de chant CPL (stratifiées)

CPL Edgings • CPL Kantenumleimer • Cantos CPL

<b>Non Encollé</b> non pre-glued ohne Schmelzkleber sin cola				
			<b>l.</b>	<b>23 mm</b>
			<b>L.</b>	<b>100 ml</b>
Type	Code	Décor	Surface	Ref Pdt
Blanc	P 099	Blanc • White • weiss • blanco	L	120036 8
			G	120025 2

<b>Pré Encollé</b> pre-glued mit Schmelzklebe con cola				
			<b>l.</b>	<b>42 mm</b>
			<b>L.</b>	<b>4,2 ml</b>
Type	Code	Décor	Surface	Ref Pdt
Métal Minéral	S 5138	Béton griffé • Concrete • Beton • Hormigón		121819 6
	S 5187	Inox brossé alliage Stainless steel • Rostfreier Stahl • Acero inoxidable		121823 3
	S 5188	Caldera • Mineral light • Mineral licht • Mineral claro		121821 9
	S 5189	Trieste Mineral dark • Mineral dunkel • Mineral oscuro		121825 7
Bois	S 5037	Chêne du québec • Oak • Eiche • Roble		121592 8
	S 5106	Chêne bastide • Oak • Eiche • Roble		121593 5
	S 5107	Chêne des marais • Oak • Eiche • Roble		121594 2
	S 5120	Chêne topia • Oak • Eiche • Roble		121817 2
Textile	S 5108	Textus poivre • Grey • Grau • Gris		121595 9
	S 5109	Textus gris • Grey • Grau • Gris		121596 6



## Araseurs de chant

Edge banding trimmer • Kantenhobel • Refilador

**Pour une meilleure finition des chants des supports de type aggloméré, MDF, contreplaqué**

For a better edge finish on chipboard, MDF, plywood • Für eine bessere Fertigung der Kanten auf Spanplatten, MDF, Sperrholz • Para un mejor acabado de los cantos sobre aglomerado, MDF, contrachapado

### Araseur simple

Single sided edge trimmer  
Kantenhobel • Refilador simple



**Araseur simple**  
Single sided edge trimmer  
Kantenhobel • Refilador simple

Ref Pdt 650100 2



**3 lames**  
Blades • Klingen • Cuchillas

Ref Pdt 650200 9



✓ **Lame réversible**  
Reversible blade  
Kombiklingen  
Cuchilla reversible

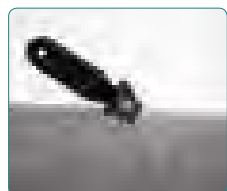

### Araseur double

Double sided edge trimmer • Doppel-Klingen-Kantenhobel Refilador doble



**Araseur double** Double sided edge trimmer • Doppel-Klingen-Kantenhobel • Refilador doble

Ref Pdt 650400 3

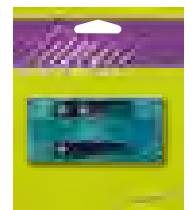

**6 lames**  
Blades • Klingen • Cuchillas

Ref Pdt 650500 0



✓ **Pour l'arasement en même temps des deux côtés**  
To level simultaneously on both sides • Für die Nivellierung auf beiden Seiten gleichzeitig  
• Para la nivelación simultáneamente en ambos lados

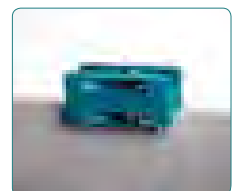









## Gamme Polyrey / Nordlinger. Bandes de chant mélaminées CPL (stratifiées)

Encollées et non-encollées en +/- 0,35 mm

En partenariat avec POLYREY, nous avons élaboré la gamme chants correspondant aux références de la gamme PANOPREY® 2017.

 Collection 2017 • 156 Complémentaires						
Décor Panneau PANOPREY® - Panneau Mélangé Polyrey		Pré encollé pre-glued • mit Schmelzklebe con cola l. 23 mm L. 25 ml 	Non Encollé non pre-glued • ohne Schmelzkleber sin cola l. 23 mm L. 150 ml 	Décor Bande de Chant		
Code	Décor	Ref Pdt Npro	Ref Pdt Npro	Coloris	Finition	
005	Noir classique	121293	130130	N005	Satin	
030	Blanco especial	121275	130112	B070		
149	Gris paloma	121600	130411	0149		
156	Crème classique	121290	130127	C017		
A014	Aiguë marine	121281	130118	A014	Satin	
A022	Acajou de floride	121324	130161	A022		
A036	Amandine	121348	130187	A036		
A057	Aulne naturel	121277	130114	A057		
A103	Argile sablée	121628	130439	A103	Mat	
B001	Bleu flash	121344	130181	B001	Satin	
B014	Blanc avoriaz	121289	130126	B014		
B015	Blanc menuires	121275	130112	B070		
B023	Bois de pécan	121349	130188	B023		
B031	Borneo naturel	121602	130413	B031	Satin	
B048	Bleu oslo	121309	130146	B048		
B068	Blanc chamonix	121275	130112	B070		
B069	Blanc courchevel	121282	130119	B069		
B070	Blanc megève	121275	130112	B070	Satin	
B086	Bleu caraïbes	121283	130120	B086		
B092	Brossé gris	121311	130148	B092		
B094	Brushed copper	121630	130441	B094		
B099	Brushed métal	121631	130442	B099	Satin	
B100	Banjan blanchi	121236	130073	B100		
B101	Banjan noirci	121241	130078	B101		
B102	Bouleau de sibérie	121604	130415	B102		Mat
B116	Beige nature	121641	130452	B116	Satin	
B117	Blanc artic	121282	130119	B069		
B118	Bleu nuit	121642	130453	B118		
B119	Bleu turquoise	121643	130454	B119		
B120	Brique	121644	130455	B120	Satin	
B131	Bouleau argenté	121603	130414	B131		
B134	Béton griffé	121629	130440	B134		Mat
C003	Chêne de macédoine	121607	130418	C003		Satin
C004	Charme d'amboise	121267	130104	C004		
C014	Chêne cérusé	121321	130158	C014		
C017	Coquille d'œuf	121290	130127	C017		
C026	Coco foncé	121665	130476	C026	Satin	
C047	Chêne wengé	121339	130176	T020		
C062	Capucine	121243	130080	C062		
C091	Chêne de fil brun	121339	130176	T020		
C092	Chêne de compiègne	121607	130418	C003	Satin	
C098	Chêne de fil naturel	121291	130128	C098		
C101	Chêne brun horizontal	121244	130081	C101		
C102	Chêne clair horizontal	121245	130082	C102		



Décor Panneau PANOPREY® Panneau Mésaminé Polyrey		 <b>Pré encollé</b> pre-glued • mit Schmelzklebe con cola l. 23 mm L. 25 ml 		<b>Non Encollé</b> non pre-glued • ohne Schmelzkleber sin cola l. 23 mm L. 150 ml 		Décor Bande de Chant			
Code	Décor	Ref	Pdt	Npro	Ref	Pdt	Npro	Coloris	Finition
C103	Chêne lavé			121284			130121	C103	Satin
C104	Cœur de pommier			121613			130424	C104	
C105	Chêne quebec			121457			130302	C105	Mat
C116	Chocolat			121648			130459	C116	Satin
C117	Citronnelle			121649			130460	C117	
C118	Cèdre bleu			121647			130458	C118	
C119	Cassis			121646			130457	C119	
C120	Caramel			121645			130456	C120	
C127	Chêne giverny			121609			130420	C127	Satin
C128	Chêne alaska			121664			130475	C128	Mat
C129	Chêne bastide			121625			130436	0081	
C130	Chêne topia			121611			130422	C130	Satin
C131	Chêne murano			121610			130421	C131	
C132	Chêne des marais			121608			130419	C132	Satin
C133	Chêne vendôme			121612			130423	C133	
C134	Chêne brocante			121608			130419	C132	Satin
C137	Chêne cut naturel			121605			130416	C137	
C138	Chêne cut wengé			121606			130417	C138	Satin
D018	Chêne de meymac			121292			130129	D018	
D021	Pommier de deauville			121307			130144	D021	Satin
E009	Érable blanc			121268			130105	E009	
E021	Écru			121345			130182	E021	Satin
E025	Érable wengé			121237			130074	E025	
E028	Érable nordique			121314			130151	E028	Satin
F001	Florida			121355			130194	F001	
F006	Fer			121305			130142	F006	Satin
F008	Fumée			121651			130462	F008	
F011	Fruittier ambré			121315			130152	F011	Mat
F012	Fruittier cendré			121269			130106	F012	
F013	Fruittier naturel			121318			130155	H025	Satin
F026	Feutre			121278			130115	F026	
F053	Fleur d'anis			121650			130461	F053	Satin
F056	Frêne scandinave			121626			130437	0083	
F058	Frêne cristal			121614			130425	F058	Satin
F061	Frêne montréal			121626			130437	0083	
G003	Gris perle			121316			130153	G003	Satin
G012	Grès			121235			130072	G012	
G024	Grenade			121459			130293	G024	Satin
G029	Gris tourterelle			121601			130412	G029	
G031	Genêt			121356			130195	G031	Satin
G044	Gris dauphin			121276			130113	G044	
G059	Gris orage			121285			130122	G059	Satin
G075	Gris cendré			121653			130464	G075	
G076	Gris acier			121652			130463	G076	Satin
H001	Hêtre domancy			121609			130420	C127	
H025	Pommier de honfleur			121318			130155	H025	Satin
H026	Hêtre horizontal			121616			130427	H027	
H027	Hêtre de provence			121616			130427	H027	Satin
H028	Hêtre bergen			121615			130426	H028	
H029	Hêtre stockholm			121618			130429	H029	Satin
H031	Hêtre rouvre			121617			130428	H031	
J018	Jaune gouache			121249			130086	J018	Satin
K001	Kiwi			121358			130197	K001	
L067	Lilas			121654			130465	L067	Satin
M001	Maryland clair			121632			130443	M001	
M003	Maryland foncé			121633			130444	M003	



<b>Décor Panneau PANOPREY® Panneau Mélangé Polyrey</b> 		<b>Pré encollé</b> pre-glued • mit Schmelzklebe con cola ℓ. 23 mm L. 25 ml 	<b>Non Encollé</b> non pre-glued • ohne Schmelzkleber sin cola ℓ. 23 mm L. 150 ml 	<b>Décor Bande de Chant</b>		
Code	Décor	Ref Pdt Npro	Ref Pdt Npro	Coloris	Finition	
M007	Merisier rustique	121619	130430	M007	Satin	
M090	Merisier clair	121292	130129	D018		
M091	Merisier ambré	121319	130156	M091		
M100	Muscade	121655	130466	M100	Satin	
M105	Merisier horizontal	121666	130477	M105		
M106	Mosaïc blanc	121634	130445	M106		
M107	Mosaïc gris	121635	130446	M107	Satin	
N002	Néon	121656	130467	N002		
N003	Noyer du périgord	121333	130170	N010		
N005	Noir	121293	130130	N005	Satin	
N010	Noyer perlé	121333	130170	N010		
N024	Noyer tropical	121454	130299	T025		Mat
N026	Noyer ombré	121253	130090	N026	Satin	
N027	Noyer vénitien	121254	130091	N027		
N056	Noisetier naturel	121621	130432	N056		Mat
N057	Noisetier brun	121620	130431	N057		
O030	Olivier de séville	121255	130092	O030	Satin	
O077	Orchidée	121657	130468	O077		
O078	Orme de nancy	121624	130435	O078		Mat
O079	Orme armagnac	121622	130433	O079		
O081	Orme des flandres	121625	130436	O081	Satin	
O082	Orme d'autrefois	121623	130434	O082		
O083	Orme lubéron	121626	130437	O083		Satin
P001	Pierre de lune	121287	130124	P001	Satin	
P009	Poirier de corréze	121338	130175	P009		
P039	Poirier des flandres	121329	130166	P039		Satin
P067	Poirier naturel	121368	130221	P067		
P092	Pomme verte	121298	130135	P092	Satin	
P112	Prune	121658	130469	P112		
P115	Palmier brun horizontal	121667	130478	P115		Satin
P118	Pin argent	121614	130425	F058		
P119	Pin moka	121627	130438	P119	Mat	
P120	Pierre de lave	121636	130447	P120		
R021	Rose tendre	121362	130201	R021		Satin
R036	Rouge cerise	121299	130136	R036		
R044	Rose dragée	121660	130471	R044	Mat	
R045	Rose pivoine	121661	130472	R045		
R049	Rouille	121637	130448	R049		Satin
S040	Cérusé clair	121301	130138	S040		
S066	Sable mouillé	121662	130473	S066	Mat	
T006	Tectonica	121638	130449	T006		
T020	Toraja wood	121339	130176	T020		Satin
T025	Teck massif	121454	130299	T025	Mat	
T051	Tulipier fumé	121262	130099	T051	Satin	
T052	Tulipier tabac	121263	130100	T052		
T063	Terre d'ombre	121663	130474	T063		Mat
T086	Textus gris	121639	130450	T086		
T087	Textus poivre	121640	130451	T087	Satin	
V011	Vert d'eau	121455	130300	V011		
V014	Vinyle	121265	130102	V014		Satin
Y022	Rose bougainvillée	121659	130470	Y022		
Z002	Zebra moka	121304	130141	Z002	Satin	
Z008	Zebrano naturel	121337	130174	Z008		
Z009	Zebrano ambré	121266	130103	Z009		
Z021	Zeste citron vert	121668	130479	Z021		
Z023	Zeste orange	121669	130480	Z023		



## Concordances Egger Formica-Unilin Krono

Correspondence  
Übereinstimmung  
Correlacion



Chants  
mélaminés  
Melamine edgings  
Melamin  
Kantenumleimer  
Cantos Melamínicos

Pré encollé  
pre-glued  
mit  
Schmelzklebe  
con cola  
L. 23 mm  
L. 25 ml

# EGGER

### Décor panneau

Code	Décor	Ref Pdt
W908 SM	Blanc craie	075317
W908 ST2		074458
W980 SM	Blanc kaolin	075317
W980 ST2		074458
U708 ST15	Gris clair	074380
U763 ST15	Gris perle	-
U999 ST2	Noir	074385
F509 ST2	Aluminium	070327
F583 ST2	Filigrane brun	-
H3332 ST10	Chêne nebraska gris	121763
H3734 ST9	Noyer de bourgogne naturel	070791
H1887 ST9	Érable de starnberg	-
H1733 ST9	Bouleau de maineau	-
H1615 ST9	Merisier romana	-
H3128 ST15	Merano naturel	-
H3031 ST9	Olivier de cordoue foncé	121793
H3025 ST15	Makassar	070792
H3704 ST15	Noyer aïda naturel	-
H1334 ST9	Chêne de ferrare clair	-
H3389 ST11	Chêne naturel clair	074419
H1502 ST15	Aulne	-
H1582 ST15	Hêtre du tyrol	-
H1920 ST9	Hêtre de lyons naturel	070161
H1511 ST15	Hêtre de bavière	-
H1706 ST15	Merisier	-
H3113 ST15	Poirier de lindau	-
H1951 ST15	Calvados sardeine	-
U999 ST11	Noir	074675
U999 ST30		070788
H078 ST79	Hêtre dosse	-
H806 ST9	Chêne anthracite transversal	070793

# FORMICA UNILIN

### Décor panneau

Code	Décor	Ref Pdt
F7949 Mat / W13 CST	Soft white	074458
F8761 Mat / UD72 CST	Jasmina	121765
F8760 Mat / UD59 CST	Creamy	121758
F8733 Mat / U127 CST	Dune beige	121756
F8751 Mat / U287 CST	Mojave	121780
F8750 Mat / U284 CST	Mokka	121785
F8757 Mat / U288 CST	Choco	121794
F8753 Mat / U282 CST	Fondant	121761
K3210 Mat / U279 CST	Levante	121796
F2962 Mat / U272 CST	Clementine	121767
F7845 Mat / U273 CST	Spectrum red	121789
F8752 Mat / U281 CST	Vino	121771
F0231 Mat / U268 CST	Peaceful blue	121753
F0232 Mat / U275 CST	Juicy pink	121790
F8754 Mat / U283 CST	Violetta	121762
F8755 Mat / U285 CST	Lemon	121787
F8763 Mat / UD96 CST	Silicon	075497
K2020 Mat / UD26 CST	Tornado	121774
K1097 Mat / U129 CST	Citadel	121768
F8762 Mat / UD81 CST	Quartz	121773
F2253 Mat / UD35 CST	Diamond black	074385
F8946 SMT / H720 BST	White birch	071632
F8940 Mat / H609 CST	Vichy pear	-
F8927 Smt / H339 BST	Solara oak	070326
F8936 Smt / H561 BST	Italian walnut	121783
F8939 Mat / H607 CST	Canadian walnut	-
F8929 Mat / H470 CST	Royal cherry	070060
F8935 Mat / H555 CST	Java walnut	121752
F8920 Mat / H304 CST	Patina oak	121791
F8971 Smt / H863 BST	Etna oak	121759
F8963 Smt / H349 BST	Urban oak	121760
F8924 Smt / H336 BST	Verona oak	070793
F8967 Smt / H892 BST	Logan oak	121792
F8765 Mat / F934 CST	Alu	070327

Chants  
mélaminés  
Melamine edgings  
Melamin  
Kantenumleimer  
Cantos Melamínicos

Pré encollé  
pre-glued  
mit  
Schmelzklebe  
con cola  
L. 23 mm  
L. 25 ml

# KRONOSPAN

### Décor panneau

Code	Décor	Ref Pdt
K101 SM	Blanc faces	075336
K101 PE		075337
K100 SM		075336
K100 PE	Blanc edelweiss	075337
U109 BS	Coquille d'œuf	121765
U514 PE	Ivoire	070125
U522 SM	Beige	074480
U522 PE		070125
U112 SM	Gris	121772
U112 PE		075497
U162 PE		Graphite
U106 PE	Blanc perle	074458
U1302 BS	Beige labo	121770
U119 PE	Beige hansa	121756
U179 PE	Gris caillou	-
U164 PE	Anthracite	121773
U190 PE	Noir	074385
U190 SM		074372
U190 SE		074675
U504 PE	Maïs	121758
U1301 PE	Vanille	121758
U2645 PE	Orange jaffa	121796
U148 PE	Rouge corail	121789
U2511 PE	Bordeaux	121771
U131 PE	Jaune	-
U2500 PE	Lipstick	121771
U2510 PE	Carafes	121753
U2512 PE	Havana	121794
D495 PE	Elysée	121777
D2566 PE	Twist	121795
D2813 VL	Ardoise	121788
D1309 WF	Aluminium	121754
D853 WF	Titan	121754
U191 PE	Gris clair	075497
D375 PE	Érable	070312
D2514 PE	Woodstock	121766
D7935 PE	Prunier wallis	121781
D2813 PE	Ardoise	121788
D2520 PE	Split	121788
D2210 VL	Cœur de hêtre	-
D1489 BS	Érable blanc	-
D1783 BS	Mangfall	075891
D2533 NA	Érable gotland	071632
D391 PR	Hêtre clair	121776
D381 PR	Hêtre	-
D382 PR	Hêtre rouge	074452
D375 PR	Érable	-
D2693 NA	Chêne velvet	-
D2240 VL	Chêne niagara	-
D741 PR	Chêne foncé	-
D2216 VL	Chêne chamonix	121782
D339 PR	Frêne blanc	-
D1432 BS	Bouleau luna	-
D2541 NA	Swiss elm froid	121757
D1350 BS	Pommier clair	121755
D991 BS	Pommier trentino	121775
D1251 VL	Poirier clair andora	121764
D1353 BS	Poirier clair	121786
D727 BS	Poirier	-
D227 BS	Poirier naturel	-
D355 PR	Pin de fil	074418
D2531 VL	Pin toscane	121784
D344 PR	Cerisier	121779
D1361 BS	Cerisier nevada	121779
D2342 VL	Teak miel	121769
D1378 BS	Wengé ebony	-
D722 PR	Noyer	070790
D2284 BS	Zebrano	121797
D620 PR	Aulne naturel	121778
D1243 BS	Nocerry	121781
D2441 BS	Makassar	070792
K101 Brillant	Blanc faces	070789
U190 Brillant	Noir	070788

### Chants mélaminés

Melamine edgings  
Melamin  
Kantenumleimer  
Cantos Melamínicos

### Pré encollé

pre-glued • mit  
Schmelzklebe  
con cola

L. 23 mm

L. 25 ml



## Placage bois

Wood veneer • Echtholz Furniere  
Chapa madera

L. 2,50 ml Ep. 0,6 mm

u.c. x 1



## Illustrations d'utilisation

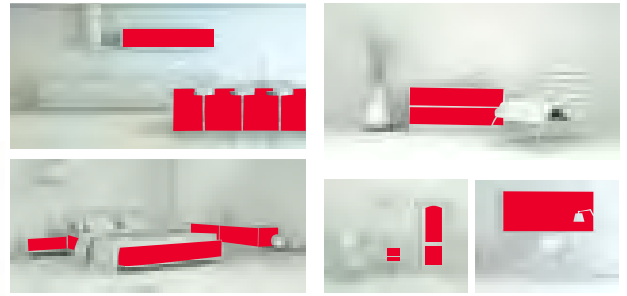

**Non Encollé  
(Plac-nor)**

non pre-glued  
ohne Schmelzkleber  
sin cola

**Pré Encollé  
(Plac-fix)**

pre-glued  
mit Schmelzklebe  
con cola

l.

25 cm

50 cm

25 cm

50 cm

Décor	Ref Pdt			
	25 cm	50 cm	25 cm	50 cm
<b>Acajou</b> Mahogany • Mahogoni • Caoba	500100 8	500300 2	510000 8	510200 2
<b>Chêne</b> Oak • Eiche • Roble	500101 5	500301 9	510001 5	510201 9
<b>Hêtre</b> Beech • Buche • Haya	500111 4	500210 4	510018 3	510017 6
<b>Koto</b>	500103 9	500303 3	510003 9	510203 3
<b>Merisier</b> Cherry • Kirsche • Cerezo	500104 6	500304 0	510004 6	510204 0
<b>Noyer</b> Walnut • Nußbaum • Nogal	500105 3	500305 7	510005 3	510205 7
<b>Pin</b> Pine • Kiefer • Pino	500107 7	500307 1	510007 7	510207 1
<b>Teck</b> Teak • Teakholz • Teca	500109 1	500309 5	510009 1	510209 5

## Revêtement adhésif

Self-adhesive foil  
Selbstklebefolie  
Pelcula autoadesiva

**Auto Adhésif  
(Placflex)**

Self-adhesive • Selbstklebend  
Autoadhesivo

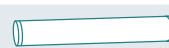

l.

0,90 ml

L.

2,15 ml

u.c.

x 1

Décor	Ref Pdt
Aluminium brossé Alu	600013 0
Blanc White • weiss • blanco	600001 7
Chêne Oak • Eiche • Roble	600002 4
Hêtre Beech • Buche • Haya	600011 6
Merisier Cherry • Kirsche • Cerezo *	600004 8
Poirier Pear • Birnbaum • Peral *	600003 1
Wengé Wenge *	600000 0
Inox	600015 4
Cuivre brossé *	600016 1
Graphite brossé *	600017 8
Relief damier alu	600014 7
Relief square alu *	600019 2
Relief square mix alu *	600020 8
Relief smart cuivre *	600021 5

\* Disponible courant 2017

\* Jusqu'à épuisement du stock

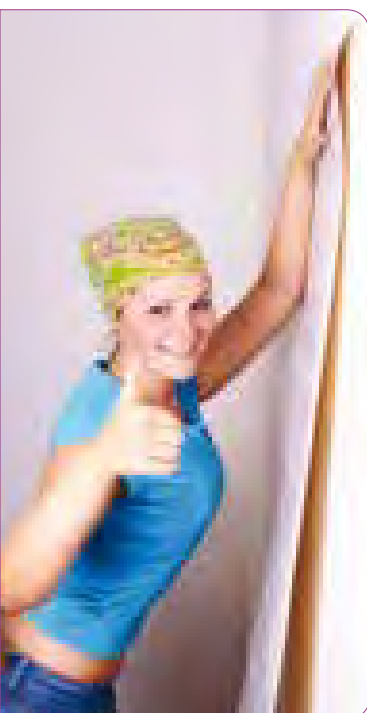

**BIEN  
VU**

Capacité :  
25 rouleaux



Ref Pdt 940121 7



## Plaque composite Alu

Aluminum Composite Panel  
Aluminium-Verbundplatte  
Panel de aluminio y composite

ALU |  BLANC | L. 120 cm | H. 80 cm | Ep. 3 mm  
 u.c. x 1

Décor	Ref Pdt
Blanc White • weiss • blanco	780029 6
Aluminium brossé Alu	780028 9
Champagne brossé	780038 8
Black Silver	780039 5

NOUVEAU

AVANT Before • Vorher • Antes



APRÈS After • Nachher • Después

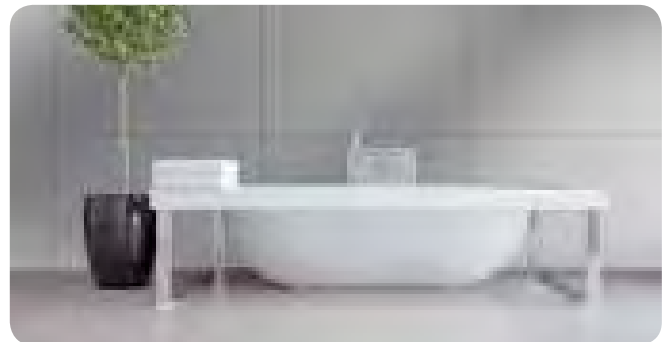

- ✓ Léger
- ✓ Facile à découper
- ✓ Facile à fixer

Light • Leicht • Ligero  
Easy to cut • Einfach zu schneiden • Fácil de cortar  
Easy to install • Einfach zu befestigen • Fácil de instalar

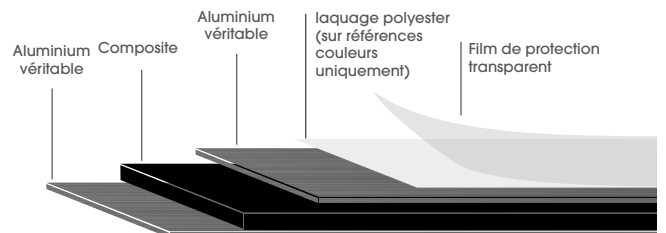

### Présentoir

MÉTAL | u.c. x 50

BIEN VU



Ref Pdt 940157 6

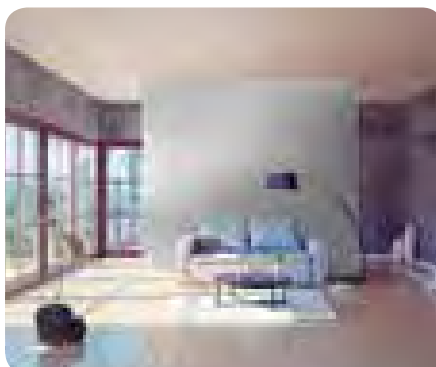

### Profil de finition

L. 122 cm | Ep. 3 mm | u.c. x 12

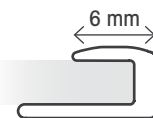

Ref Pdt 780041 8

### Profil de jonction bord à bord

L. 122 cm | Ep. 3 mm | u.c. x 12

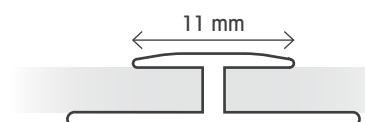

Ref Pdt 780042 5



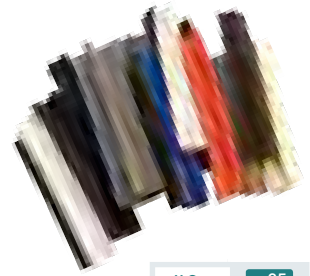

## Profilés plastiques

Plastic Profile • Plástica Profile • Perfiles plásticos

### Angle

Désignation	Couleur	ℓ.	L.	Ref Pdt
<b>Profilé de renvoi d'angle (YR)</b> Reversing angle profile Doppel-Eck-Profil Perfil doble ángulo	Blanc White Weiss Blanco	16 mm	2,75 ml	670051 1
		19 mm		670050 4
<b>Profilé de construction d'angle (PCA)</b> Profile for angle construction Bauprofil für winkel Perfil construcción de angulo	Blanc White Weiss Blanco	18-19 mm		670184 6
<b>Profilé Quart de rond (PQR)</b> Quarter round profile Viertel kreis profil Perfil cuarto de luna	Blanc White Weiss Blanco	15 x 15 mm	3 ml	670075 7
<b>Cornière de finition (LR)</b> Finishing profile Fertigstellung Eck-profil Perfil de terminación	Blanc White Weiss Blanco	15 mm	2,75 ml	670084 9
		20 mm		670052 8
		25 mm		670091 7
		30 mm		670085 6
		35 mm		670086 3
		40 mm		670087 0
50 mm	670088 7			

### Jonction de panneaux

Désignation	Couleur	ℓ.	L.	Ref Pdt
<b>Profilé en H de raccord (HR)</b> H profile H Profil Perfil plastico en H	Blanc White Weiss Blanco	3-4 mm	2,75 ml	670096 2
		10 mm		670115 0
		16 mm		670049 8
		19 mm		670048 1
<b>Profilé en T de raccord (TR)</b> T Profile T Profil Perfil en T	Blanc White Weiss Blanco	25-18 mm	2,75 ml	670169 3



### Chant du Panneau

Chant rigide type U (UR) U Type rigid edgings  
U Förmige Hart Kanten • Perfiles U rigido

u.c. x 25

ℓ.	8 mm	10 mm	12 mm	16 mm	19 mm	22 mm
	L.	2,75 ml				
Décor	Ref Pdt					
Blanc White • Weiss • Blanco	670093 1	670037 5	670038 2	670039 9	670036 8	670040 5
Noir Black • Schwarz • Negro	-	-	-	-	670064 1	-
Gris Grey • Grau • Grisalla	-	-	-	-	670065 8	-
Chêne clair Oak • Eiche • Roble	-	-	-	-	670062 7	-
Hêtre Beech • Buche • Haya	-	-	-	-	670070 2	-

### Profilé «Queue de sapein»

Thermo-plastic edge "T" profile • Thermo-plastisches "T" profil • Perfiles termo-plásticos tipo "Espina de pescado"



Arasable (QSA) Anchnittsfähig • Retilable

ℓ.	15-21 mm	21-26 mm
	L.	25 ml
Décor	Ref Pdt	
Blanc White • Weiss • Blanco	720019 5	-
Noir Black • Schwarz • Negro	720020 1	019017 2
Gris/Noir Grey/Black • Grau/Schwarz Grisalla/Negro	720022 5	019011 0

Couvre chant souple (CCS) Soft plastic covering edgings  
Umschließende Weichkunststoff-kanten • Cubrecantos flexible

u.c. x 1

ℓ.	16 mm	19 mm	16 mm	19 mm
	L.	2 ml		25 ml
Décor	Ref Pdt			
Blanc White • Weiss • Blanco	670000 9	670009 2	670054 2	670041 2
Noir Black • Schwarz • Negro	670001 6	670010 8	670053 5	670118 1
Aluminium Alu	670128 0	670129 7	670147 1	670146 4
Chêne clair Oak • Eiche • Roble	670006 1	670015 3	670061 0	670148 8
Hêtre clair Beech • Buche • Haya	670007 8	670016 0	670059 7	670108 2
Merisier Cherry • Kirsche • Cerezo	670008 5	670017 7	670060 3	670068 9

Demi-rond creux (QSDC) Empty half round • Halbrund hohl  
Media luna hueco

u.c. x 1

ℓ.	20 mm	25 mm	30 mm
	L.	25 ml	
Décor	Ref Pdt		
Blanc White • Weiss • Blanco	019004 2	-	-
Bleu Blue • Blau • Azul	019022 6	-	-
Gris Grey • Grau • Grisalla	019002 8	019007 3	019010 3
Noir Black • Schwarz • Negro	019001 1	019008 0	019009 7
Rouge Red • Rot • Rojo	019005 9	-	-

Demi-rond plein (QSP) Full half round • Halbrund fach, massiv  
Media luna macizo

u.c. x 1

L.	100 ml	ℓ.	19 mm
Décor	Ref Pdt		
Blanc White • Weiss • Blanco	019013 4		
Noir Black • Schwarz • Negro	019012 7		

\* Jusqu'à épuisement du stock



**CUISINE**  
**CRÉDENCE**  
**PLAN DE TRAVAIL**



**Profil alu** Profiles • Profile • Perfiles

L. ± 670 mm

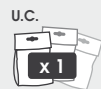

- Bien identifier la forme du plan, son épaisseur et son rayon de section.
- L'outil malin pour vous aider à choisir le profil correspondant à votre plan de travail. Pour cela, utilisez les gabarits à l'échelle ci-dessous.

Information for identification of the board, thickness and radius  
Informationen zur Klassifizierung der Platte, Stärke und Radius  
Identificar la forma de la encimera, su espesor y su radio

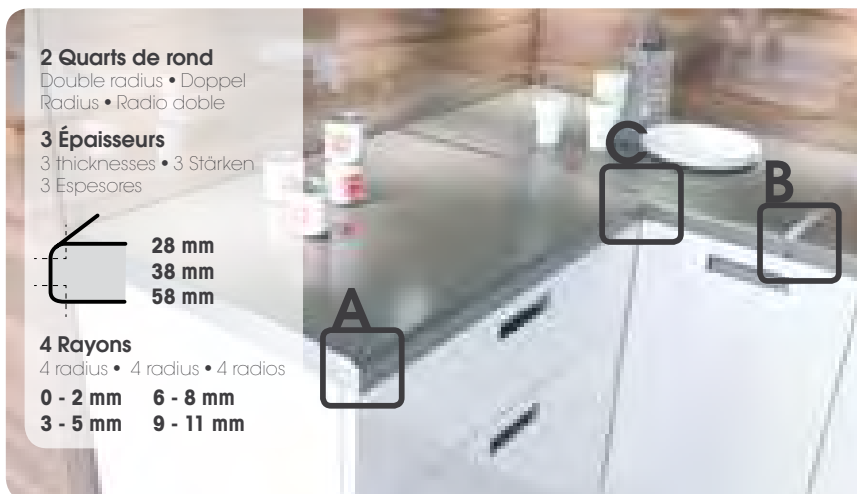

**2 Quarts de rond**  
Double radius • Doppel Radius • Radio doble

**3 Épaisseurs**  
3 thicknesses • 3 Stärken  
3 Espesores

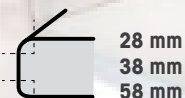

**4 Rayons**  
4 radius • 4 radius • 4 radios  
0 - 2 mm    6 - 8 mm  
3 - 5 mm    9 - 11 mm

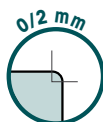
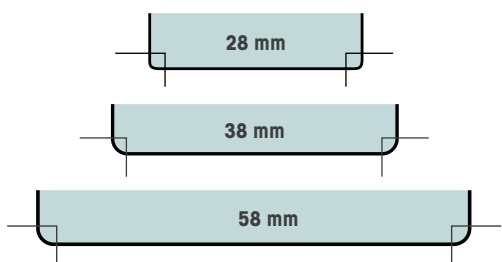

A	B	C
<b>Finition bordure</b> End cap profile Endkappenprofil Terminación Reborde	<b>Jonction bord à bord</b> Straight run joint profile Gerades Verbindungsprofil Unión	<b>Jonction d'angle</b> Corner joint profile Verbindungsprofil Unión de angulo

Ep. 28 mm 38 mm 58 mm 28 mm 38 mm 58 mm 28 mm 38 mm 58 mm

Décor	Ref Pdt								
Aluminium Alu	680176 8	680151 5	680154 6	680177 5	680152 2	680155 3	680178 2	680153 9	680156 0

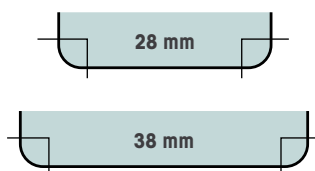

A	B	C	
<b>Ep.</b>	28 mm 38 mm	28 mm 38 mm	28 mm 38 mm

Décor	Ref Pdt					
Aluminium Alu	680106 5	680100 3	680124 9	680118 8	680115 7	680109 6
Blanc White • Weiss • Bianco	680107 2	680101 0	680125 6	680119 5	680116 4	680110 2
Noir Black • Schwarz • Negro	680108 9	680102 7	680126 3	680120 1	680117 1	680111 9

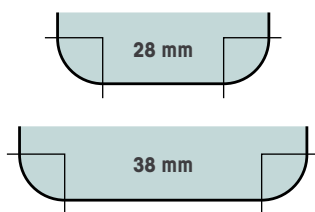

A	B	C	
<b>Ep.</b>	28 mm 38 mm	28 mm 38 mm	28 mm 38 mm

Décor	Ref Pdt					
Aluminium Alu	680145 4	680014 3	680147 8	680016 7	680146 1	680015 0
Blanc White • Weiss • Bianco	680148 5	680017 4	680149 2	680020 4	680150 8	680023 5

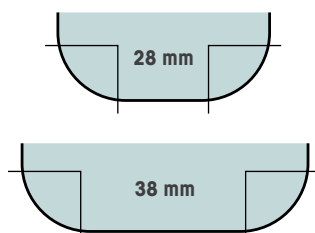

A	B	C	
<b>Ep.</b>	28 mm 38 mm	28 mm 38 mm	28 mm 38 mm

Décor	Ref Pdt					
Aluminium Alu	680002 0	680112 6	680008 2	680113 3	680011 2	680114 0
Blanc White • Weiss • Bianco	680004 4 *	680142 3	-	680143 0	-	680144 7

\* Jusqu'à épaisseur du stock



## I Support de snack Breakfast bar • Snack Bodenträger • Soporte de estante snack

- Pour créer un espace bar/snack convivial ; une console desserte dans une cuisine ouverte, ou simplement pour disposer de plus d'espace de travail

To create a friendly bar / snack area , a service shelf in an open kitchen or simply to have more workspace

Um eine freundliche Bar / Snack-Bereich, ein Service Regal in einer offenen Küche zu schaffen oder einfach, um mehr Arbeitsfläche haben

Para crear un espacio barra / snack agradable , un estante de servicio en una cocina abierta, o simplemente para tener más espacio de trabajo.

## I Support de snack Zen



ALU ANODISÉ



- Pied mono bloc
- Matériau : aluminium anodisé
- Vis inox fournies

Monoblock stand • Integralträger • Soporte monobloque.  
Anodized aluminum • Eloxiertem Aluminium  
Aluminio anodizado.

Stainless steel screws provided • Mit Edelstahl-Schrauben •  
Con Tornillos de acero inoxidable.



Ref Pdt 780011 1

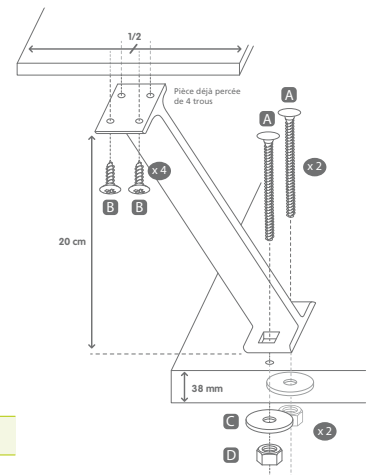

## I Support de snack Urban \* alu basic design



ALU



- Hauteur posé : 20 cm
- Monobloc / Pré-percé
- Quincaillerie fournie
- Aluminium véritable
- Rapport qualité/prix

Installed height • Montagehöhe •  
Altura de instalación

One-piece bracket / With screw holes • Integralträger /  
Vorgebohrt • Soporte monobloque / Preperforado

Hardware provided • Kleinteile inkl • Herrajes incluidos

Genuine aluminium • Aluminium • Aluminio auténtico

Excellent value • Sehr gutes Preis / Leistungsverhältnis •  
Excelente relación calidad-precio



\* Disponible courant 2017

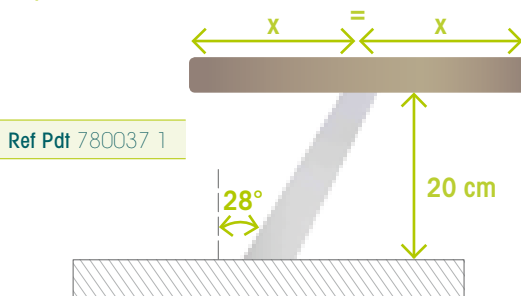

Ref Pdt 780037 1

## I Support de snack incliné (21 cm LUX - finition inox brossé)



ACIER



- Hauteur posé : 21 cm
- Quincaillerie
- Notice de pose fournies
- Discret et Design

Installed height • Montagehöhe •  
Altura de instalación

Hardware provided • Kleinteile inkl • Herrajes incluidos

Fitting instructions included • Mit Montageanleitung •  
Instrucciones de montaje incluidas

Discreet and stylish • Formschön und diskret • Discreto  
y de diseño

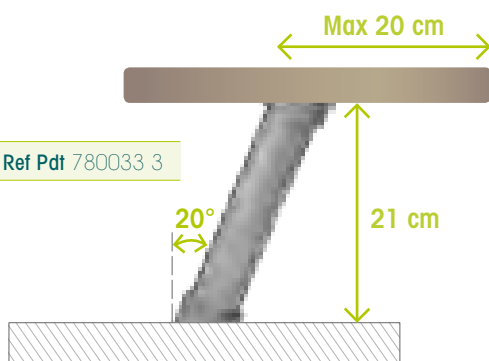

Ref Pdt 780033 3



## Fond de hotte

Stainless steel backsplash tiles • Edelstahl-Spritzschutzplatten • Placas murales de cocina



L.60 cm H.70 cm [Ref Pdt 780016 6](#)

L.90 cm H.70 cm [Ref Pdt 780017 3](#)



- ✓ Facile à installer
- ✓ Préserve la propreté des murs
- ✓ Se pose derrière tout type de plaque de cuisson

Easy to install • Einfach zu installieren • Instalacion fácil.

Maintains walls clean • Behält die Sauberkeit der Wände • Mantiene las paredes limpias.

Behind any type of hob • Hinter jedem Kochfeld • Detrás de cualquier tipo de encimera

## Crédence basse

Stainless steel backsplash tiles • Edelstahl-Spritzschutzplatten • Placas murales de cocina



[Ref Pdt 780018 0](#)



- ✓ Esthétique : accord parfait avec le fond de hotte inox
- ✓ Solution économique

Good value for money • Effiziente Lösung  
Solución económica





CUISINE  
CRÉDENCE  
PLAN DE TRAVAIL

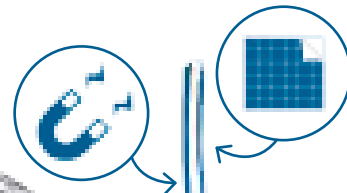

## Réglette LED sans fil à détection de mouvement

NOUVEAU

Wireless LED light with motion sensor  
Wireless-LED-Licht mit Bewegungssensor  
Luz LED inalámbrica con sensor de movimiento

LED BLANC | L. 19 cm H. 3 cm Ep. 1,5 cm

x 1 | U.C. x 5

Ref Pdt 780040 1



- ✓ Fixation simple : languette aimantée et adhésive
  - ✓ Sans fil - Fontionne avec 4 piles AAA (non incluses)
  - ✓ Zone de détection 140° et jusqu'à 5m en situation d'obscurité
  - ✓ Basse consommation - luminosité : 30 Lumens
- Easy to install (magnetic and adhesive backing) • Einfache Befestigung: Magnetlasche mit Haftschicht • Fijación simple: lengüeta imantada y adhesiva

Wireless. Uses 4 x AAA batteries (not included) • Drahtlos. Versorgung durch 4 Batterien AAA (kein Lieferumfang) • Inalámbrica. Funciona con 4 pilas AAA (no incluidas)

Sensor range of 140° and up to 5 m in darkness • Leuchtbereich 140°, bei Dunkelheit bis zu 5 m • Zona de detección de 140° y hasta 5 m en la oscuridad

Low power consumption. Brightness: 30 lm (lumens) • Niedriger Verbrauch. Lichtstärke: 30 lm (Lumen) • Bajo consumo. Luminosidad: 30 lm (lúmenes)

## Profil de finition de crédence

backsplash finishing profile  
Abschlussprofil für Küchenwand  
Perfil de acabado pared de cocina

ALU ANODISÉ | L. 3,15 m | x 1 | U.C. x 8 | Silicon

- Adapté aux crédences de 8 à 10 mm
- Matériau : aluminium anodisé

Fits backsplash tiles from 8 to 10 mm • Passend. Fliesen von 8 bis 10 mm Se adapta a azulejos de 8 a 10 mm  
Anodized aluminum • Eloxiertem aluminium • Aluminio anodizado

Ref Pdt 670209 6



- ✓ Simple et rapide à poser
- ✓ Esthétique et durable

Quick and easy to install • Einfach und schnell zu installieren • Sencillo e instalación rápida

Beautiful and sustainable • Schön und nachhaltig • Estético y sostenible



## Top protect Baguettes repose plat

Trivet blades • Topfuntersetzer Klingen  
Tiras salvamantel

INOX | L. 25 cm H. 1 cm Ep. 2,5 mm | x 5

U.C. x 5 | Fixation : auto adhésif

Self adhesive • Verglasung • Autoadhesivo

Ref Pdt 780023 4



- ✓ Prêt à poser
- ✓ Pour tout type de plan de travail
- ✓ Gabarit de pose inclus

Ready to install • Bereit zu installieren • Listo para instalar

For any kind of working top • Für jede mögliche Küchenarbeitsplatte • Para todas las encimeras de cocina

Installation template included • Installation Vorlage enthalten • Plantilla de instalación incluido

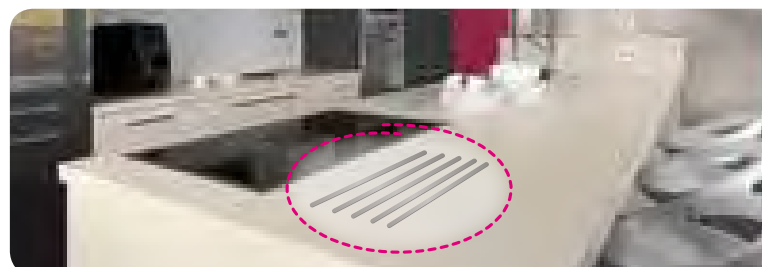



CUISINE

CRÉDENCE - ÉTANCHÉITÉ  
PLAN DE TRAVAIL



## Canules

Cannulas • Kanülen • Cànulas

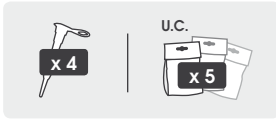

Ref Pdt 780012 8



### ✓ Compatible avec toutes les cartouches (silicone, colle, mastic)

Compatible with all cartridges (silicone, glu, putty, ...)  
Kompatibel mit allen Patronen (Silikon, Leim, Kitt, ...)  
Compatible con todos los cartuchos (silicona, pegamento, masilla, ...)



## Pare vapeur

Protective sheet • Pelicula de proteccion  
Schutzfolie

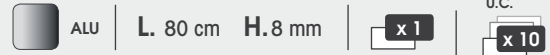

• Adhésif • Pose facile • Discret

Self adhesive • Easy to install • Discreet  
Selbstklebend • Einfache Installation • Diskret  
Auto adhesivo • Instalacion Facil • Discreto

Ref Pdt 780019 7

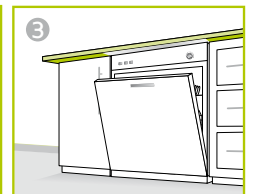
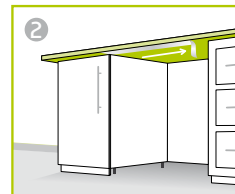
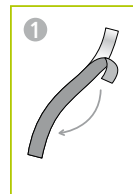

## Profil de protection de plan de travail

Profile for the protection of kitchen working tops  
Schutzprofil für Küchenarbeitsplatten  
Perfil para la protección de encimeras de cocina



L. 3,15 ml H.38 mm Ep.11 mm

Ref Pdt 780024 1

L. 3,15 ml H.28 mm Ep.11 mm

Ref Pdt 780032 6

- Pour plan de travail de 38 mm d'épaisseur
- Pour plan de travail de rayon 0 à 9 mm

For 38mm working top • Für 38 mm Arbeitsplatte  
Por encimeras de 38 mm  
For working top with 0-9mm radius • Für Arbeitsplatte mit  
0-9mm Radius • Por encimeras con radio de 0 à 9 mm



### ✓ Idéal neuf et rénovation

Perfect for new kitchen or renovation  
Perfekt für neue Küche oder Renovierung  
Perfecto para cocina nueva o renovación



## Profil pour îlot de cuisine

Kitchen island junction trim  
Küchenverbindungsprofil  
Perfil de union para cocinas

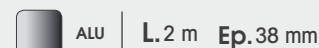

Ref Pdt 680044 0

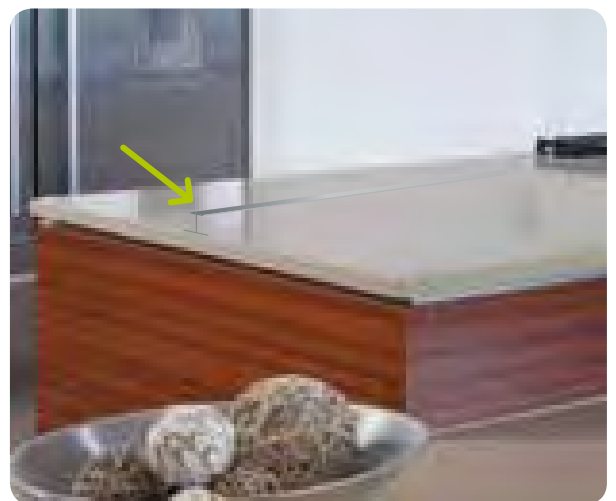



## Profil de cuisine

Backsplash Profile "PREA-D"  
Küchenprofil "PREA-D"  
Perfil de cocina "PREA-D"



ALU  
ANODISÉ

L. 3,15 m Ep. 22 mm



x 1



U.C.

x 5

Matériau : plastique + aluminium

Ref Pdt 670211 9



- ✓ Pour une parfaite finition de la cuisine (entre crédence et plan de travail)
- ✓ Très résistant à la corrosion / abrasion / rayures
- ✓ Esthétique et discret
- ✓ Idéal pour la rénovation

For a perfect finish of the kitchen • Für ein perfektes Finish der Küche • Para un buen acabado

Highly resistant to corrosion / abrasion / scratches • Hohe Beständigkeit gegen Korrosion / Abrieb / Kratzer • Muy resistente a la corrosión / abrasión / rayas

Neat and discreet • Schick und diskret • Estético y limpio

Ideal for renovation • Ideal für die Renovierung • Ideal para la renovación



## Kit de finition pour profil PREA-D

Accessory set for "PREA-D" backsplash profile  
Zubehöre für Küchenprofil "PREA-D"  
Accesorios para perfil de cocina "PREA-D"

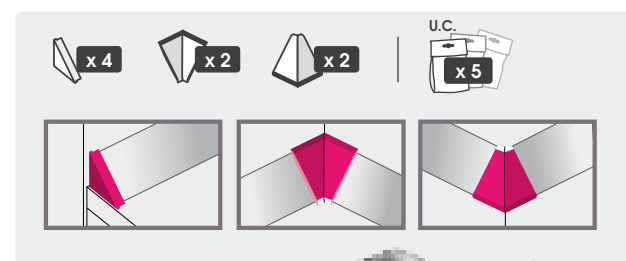

Ref Pdt 670212 6



## Profil de cuisine CARRÉ

Backsplash Profile "PREAD CARRÉ"  
Küchenprofil "PREAD CARRÉ"  
Perfil de cocina "PREAD CARRÉ"



ALU  
ANODISÉ

L. 3,15 m Ep. 11 mm H. 25 mm

Matériau : Aluminium et PVC



x 5 U.C.

Ref Pdt 670224 9

Ref kit 670225 6

### Composition du kit



x 2

ANGLE  
SORTANT



x 2

ANGLE  
RENTANT



x 4

ANGLE  
FINITION

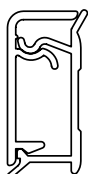

## Profils XS C et XS B

Profile • Profil • Perfil



ALU • BLANC  
NOIR

L. 3,15 m



x 1



x 1



U.C.

x 5



U.C.

x 5



Silicon



OU  
Vis



- ✓ Livré avec 4 embouts droits de finition + 2 embouts rentrants + 2 embouts sortants

Delivered with 4 flat stamps + "2 out" pieces + "2 in" pieces • Mit 4 Abschlusskappen inklusive + 2 Aussenecke + 2 Innenecke • Entregado con 4 topos laterales + 2 topos de angulo saliente + 2 topos de angulo entrante

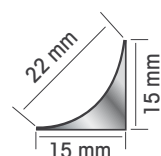

### XS C

Ref Pdt

Aluminium	670205 8
Blanc	670214 0
Noir	670213 3

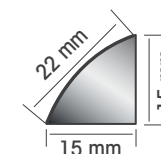

### XS B

Ref Pdt

Aluminium	670206 5
-----------	----------

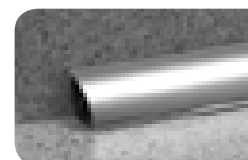
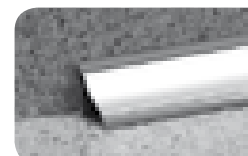



## Joint plastique

Sealing tape • Wasserdichtung  
Junta de estanqueidad



ALU



BLANC

L. 3 m



x 1

u.c.



x 5

**Pour la réalisation de joint d'étanchéité entre le plan de travail et le mur.**

To make a seal between the working top and wall  
• Eine Dichtung zwischen der Arbeitsplatte und Wand erzielen • Para lograr un sellado hermético entre la encimera y la pared

Ref Pdt

Blanc	780001 2
Gris Alu	780007 4

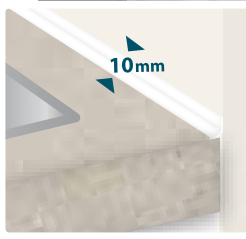
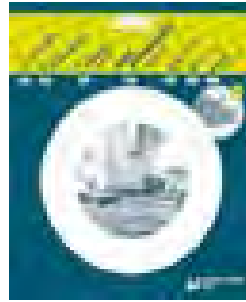

- ✓ Recoupe facile
- ✓ Discret
- ✓ Remplace avantageusement le silicone
- ✓ Épouse la forme du support

Easy to cut • Leicht zu schneiden • Corte fácil  
Discret • Diskret • Discreto  
Replaces silicone • Ersetzt Silikon • Reemplaza ventajosamente la silicona  
Conforms to the contours of the support • Passt sich der Form des Trägers • Se acopla a la forma de la base

## Mastiplast

Sealing tape • Wasserdichtung • Junta de estanqueidad



BLANC

l. 9 mm L. 3 m



x 1

u.c.



x 1

Ref Pdt 780002 9

- Cuisine, salle de bain, vitrage
- Fixation : auto adhésif

Sealing tape : self adhesive, multi-use  
Dichtung für : Verglasung, Küchen, Badezimmer  
Junta de estanqueidad : autoadhesivo, multiuso

- ✓ Facile à poser
- ✓ Étanche
- ✓ Propre

Easy to set • watertight and clean  
Einfach • Wasserdicht • Sauber  
Instalación sencilla • estanque • limpio.

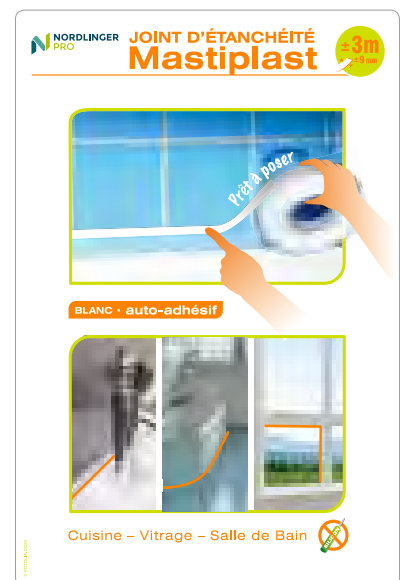





## Raccords de plinthes agglo

Fittings for skirting boards  
Anschlüsse für Sockelleisten  
Unión para rodapiés agglo

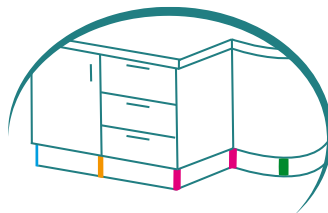

H.150 mm  
Ep.16/19 mm

U.C.

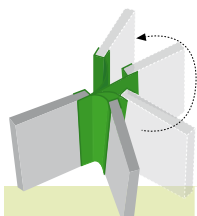

### Angle Universel

Universal corner  
Universal-Winkel  
Angulo universal



### Angle Droit

Angle Junction  
Winkelanschlussstück  
Angulo recto

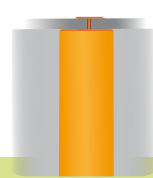

### Jonction Droite(H)

Straight Junction  
Gerade Verbindung  
Union Recta



### Profil de Finition(U)

End cap profile  
Endkappen Profil  
Perfil de acabado



### Kit raccords de Plinthe

Fittings for skirting boards • Anschlüsse für Sockelleisten • Kit uniones de rodapiés

UNIT

x 4

x 4

x 4

x 4

2U+2H+2 angles droits

Décor	Ref Pdt				
Gris alu Alu	790024 8	790027 9	790030 9	790033 0	790036 1
Blanc White • Weiss • Bianco	790025 5	790028 6	790031 6	790034 7	790037 8
Noir Black • Schwarz • Negro	790026 2	790029 3	790032 3	790035 4	790038 5

## Support micro-ondes

Microwave wall bracket  
Wandhalterung für Mikrowelle  
Soporte de pared para microondas

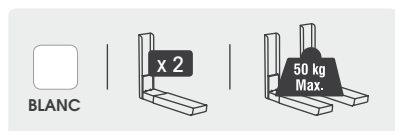

Ref Pdt 780021 0

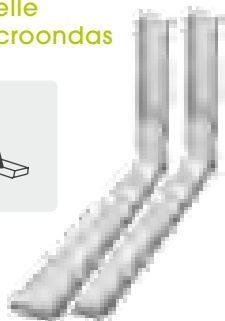

## Cache vis

Screw hider • Selbstklebende  
Abdeckkappen • Tapas autoadhesivas

BLANC • HÊTRE  
GRIS • NOIR

x 100

U.C. x 10

Ø 13 mm

Fixation : auto adhésif  
Self adhesive  
Selbstklebende  
Autoadhesivas

	Ref Pdt
Blanc	650600 7
Hêtre	650602 1
Gris	650605 2
Noir	650604 5

## U transparent

U transparent • U transparent • U transparente

U.C.



L.2,60 m Ep.16/19 mm

Pour l'étanchéité et la protection  
des plinthes de cuisine

Ref Pdt 670074 0

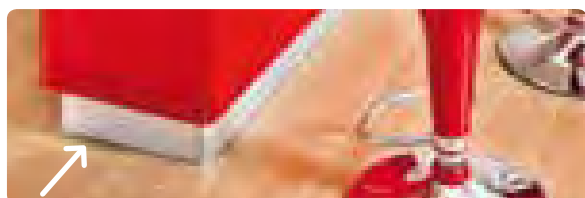

## Freins de porte

Kitchen door brake • Küchentür  
Brems • Amortiguador de  
puerta de cocina



x 4 | x 8 | U.C. x 1

Ref Pdt 780009 8

Cuisine, meuble

Kitchen, furnitue  
Küchen, nöbel  
Cocina, Mueble

x 100 | Ref Pdt 780010 4

✓ Fini les portes qui claquent !

No more slamming doors ! • Nie mehr Zuschlagen von Türen !  
No mas puertas golpeando !



SOL & MUR  
SOL



## Plinthes cache fil PVC et embouts de finition

Plastic skirting board and assembling and finition kit  
Kunststoff-Sockelleiste und montage und fertigungszubehöre  
Rodapie cubrecable PVC y topes de acabado



### Plinthes cache fil PVC

Plastic skirting board  
Kunststoff-Sockelleiste  
Rodapie cubrecable PVC

L. 2,5 m H. 6 cm Ep. 1,2 cm



#### À coller ou visser

Glue or screw mounted  
Montage mit Leim oder Schrauben  
Se instala con cola o con tornillos

### Kit de finition

Assembling and finition kit  
Montage-und fertigungszubehöre  
Kit de acabado



Kit : 2 embouts droits + 4 angles  
rentrants + 4 jonctions droites

Kit : 2 endcaps + 4 outward angles + 4 straight junctions  
Kit : 2 Endkappen + 4 Außen Winkeln + 4 gerade Kreuzungen  
Kit : 2 tapas + 4 angulos abiertos + 4 uniones rectas

	Ref Pdt
Blanc	790000 2
Chêne naturel	790001 9
Chêne blanc	790002 6
Chêne gris	790042 2
Chêne doré	790044 6
Gris *	790003 3
Gris alu	790041 5
Ardoise foncé	790045 3
<b>NOUVEAU</b> Wood 1	790061 3
Wood 2	790062 0 <b>NOUVEAU</b>
<b>NOUVEAU</b> Wood 3	790067 5
Stone 1	790071 2 <b>NOUVEAU</b>
<b>NOUVEAU</b> Stone 2	790072 9

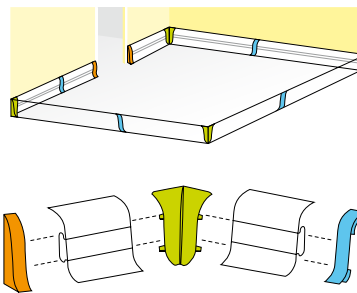

	Ref Pdt
Blanc	790004 0
Chêne naturel	790005 7
Chêne blanc	790006 4
Chêne gris	790047 7
Chêne doré	790049 1
Gris *	790007 1
Gris alu	790046 0
Ardoise foncé	790050 7
Wood 1	790075 0
Wood 2	790076 7
Wood 3	790081 1
Stone 1	790085 9
Stone 2	790086 6

\* Jusqu'à épuisement du stock



### Kit angles

Angle kit • Kit für Winkel  
Kit angulos

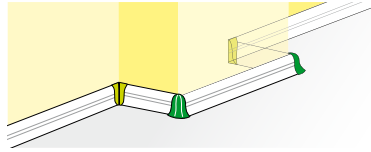

U.C.



Kit : 1 angle rentrant + 1 angle sortant

Kit : 1 outward angle + 1 inward angle  
Kit : 1 außen winkeln + 1 innen winkeln  
Kit : 1 angulo abierto + 1 angulo cerrado

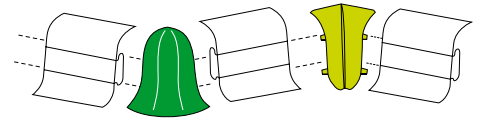

	Ref Pdt
Blanc	790012 5
Chêne naturel	790013 2
Chêne blanc	790014 9
Chêne gris	790052 1
Chêne doré	790054 5
Gris *	790015 6
Gris alu	790051 4
Ardoise foncé	790055 2

### Kit prise & jonctions

Socket and connection kit  
Kit Steckdose und Anschluss  
Kit enchufe electrico y empalmes rectos

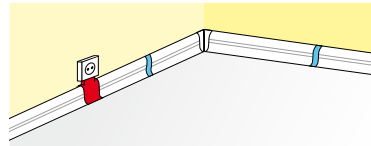

U.C.



Kit : 1 sortie de prise + 2 jonctions droites

Kit : 1 plug outlet + 2 straight junctions  
Kit : 1 steckersverbindung + 2 gerade kreuzungen  
Kit : 1 salida enchufe + 2 uniones rectas

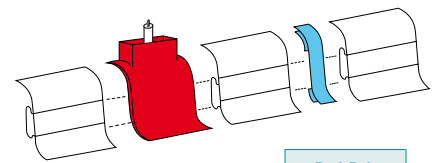

	Ref Pdt
Blanc	790020 0
Chêne naturel	790021 7
Chêne blanc	790022 4
Chêne gris *	790057 6
Chêne doré *	790059 0
Gris *	790023 1
Gris alu *	790056 9
Ardoise foncé *	790060 6

\* Jusqu'à épaisseur du stock

## Cales pour la pose du parquet

Wedges for parquet laying • Abstandskelle für die Verlegung von Parkett • Cuñas para la colocación de parquet

### Cale «lift top»



BLEU



U.C.



#### Cale de montage plastique

Plastic lifting wedge • Kunststoffhebekeil  
Cuña de elevación de plástico



Ref Pdt 740049 6



### Cale «lift XL»



JAUNE



U.C.



#### Pour la pose d'un parquet, pour soulever facilement les vitres, pour dégondrer les portes ou soulever plaques de plâtre et d'isolant.

To lay parquet flooring, to easily lift glass, to un hinge doors or lift insulation and plasterboards • Um Parkettböden zu verlegen, um leicht Glas zu heben, Türen aus den Angeln zu heben oder um Isolierung und Gipsplatten zu heben  
• Para la colocación de parquet, para levantar fácilmente los vidrios, para desquiciar puertas o levantar placas de yeso y aislamiento.

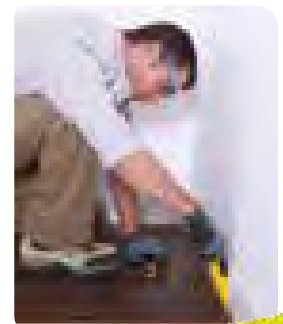

Ref Pdt 740051 9



#### Utilisable des 2 côtés

May be used on both sides • Wird auf beide Seiten verwendet • Se usa los 2 lados



SOL & MUR  
MUR



## Clips à lambris

Panelling hooks • Täferkrallen • Grapas para frisos

NOUVEAU  
DESIGN



### Clips pour lambris en pose murale

#### CLIPS + POINTES

• HOOKS + NAILS • HAKEN + NÄGELN  
• GRAPAS + CLAVOS

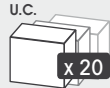

### Clips pour lambris en pose plafond

#### CLIPS + VIS

• HOOKS + SCREW • HAKEN +  
SCHAUBE • GRAPAS + TORNILLOS

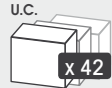

**Lambris bois** Panelling wood  
Holz Täfer - Holz • Friso Madera

	Pour lambris d'épaisseur de	±	m <sup>2</sup>	Ref Pdt
3 mm	10-12 mm	100	5	740100 4
		250	10	740101 1
4 mm	13-16 mm	250	10	740106 6
5 mm	18-21 mm	200	10	740105 9

**Lambris PVC** • Panelling PVC  
• Holz Täfer PVC • Friso PVC

	Pour lambris d'épaisseur de	±	m <sup>2</sup>	Ref Pdt
1 mm	6-12 mm	250	10	740103 5

**Lambris MDF** • Panelling MDF  
• Holz Täfer MDF • Friso MDF

	Pour lambris d'épaisseur de	±	m <sup>2</sup>	Ref Pdt
1,6 mm	6-12 mm	250	10	740104 2

	Pour lambris d'épaisseur de	±	Ref Pdt
3 mm	10-12 mm	100	740107 3



### ✓ Invisible après pose

Invisible after installation • Unsichtbar nach der Installation  
Invisible después de la instalación

## Cloueur manuel

Hand nailer • Handnagler • Aparato de clavado manual



Ref Pdt 740109 7

### ✓ Embout magnétique retenant le clou

Magnetic end to hold the nail Magnetische • Spitze, um  
den Nagel zu halten • Punta magnética para sujetar el clavo.  
Easier to instal • Einfacher zu installieren • Más fácil de instalar.

### ✓ Plus de confort de pose

Allows nailing without hurting fingers • Ermöglicht Nageln  
ohne zu verletzen Finger • Permite clavar sin lastimarse  
los dedos.

### ✓ Permet d'enfoncer le clou sans se faire mal aux doigts

## Pince à lambris

Panelling pliers • Paneelzange • Tenazas panel



Ref Pdt 740108 0

Pour le maintien de la lame durant le clipsage en pose  
plafond, permettant ainsi de poser seul le lambris.

Grâce à sa molette de réglage, plusieurs lames sont  
maintenues en suspension afin d'éviter de se déplacer  
à la pose de chaque nouvelle lame.

Holds the panel while being clipped on the ceiling ,allowing one  
person to do the work alone • Hält die Platte, während sie an der Decke  
befestigt wird , so dass eine Person die Arbeit allein machen kann •  
Mantiene el panel mientras esta fijado al techo, lo que permite a una  
persona sola de hacer el trabajo.

### ✓ Permet de poser seul du lambris au plafond

Allows one person alone to put in ceiling  
panels • Ermöglicht eine Person , allein  
Deckenplatten zu setzen • Permite que una  
sola persona pueda poner paneles de techo.  
Time saving • Zeitersparnis • Ahorra tiempo

\* Jusqu'à épuisement du stock



## Taquets d'assemblage

Wedges for panel assembling • Verbindungskeil für Sperrholzplatten • Tacos de ensamblaje para paneles

### Assemblage de tablettes, panneaux, étagères

Assembling of shelves and panels  
Befestigung von Fachböden, Paneelen und Regalen  
Fijación de estantes y paneles

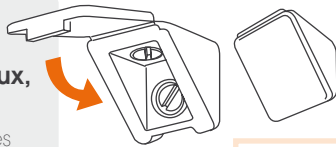

	8 Taquets 8 wedges 8 keile 8 tacos	16 Taquets 16 wedges 16 keile 16 tacos	32 Taquets 32 wedges 32 keile 32 tacos	4 Taquets double hauteur 4 double width wedges 4 doppelbreite keile 4 tacos doble anchura	8 Taquets 8 wedges 8 keile 8 tacos
U.C.	x 10	x 16	x 10	x 10	x 400
Décor	Ref Pdt				
Blanc White • weiss • blanco	740025 0	740028 1	740046 5	740048 9	740026 7
Beige	740027 4	740029 8	740047 2	-	740030 4
Gris alu Grey alu • Grau alu • Gris alu	740056 4	-	740057 1	-	-

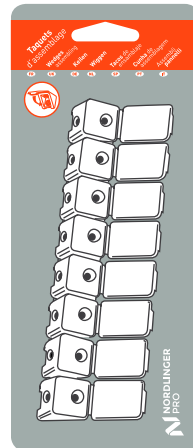

- ✓ Fixation invisible
- ✓ Permet d'assembler meuble, placard, dressing facilement et rapidement

Concealed fixing • Verdeckte Befestigung Fijación oculta

Used to assemble furniture and wardrobes quickly and easily • Um Möbel und Schränke schnell und einfach zusammenzubauen • Se utiliza para montar muebles y armarios rápidamente y fácilmente.

## Tourillons

Dowels • Dübel • Clavijas



U.C.



Ø 8 mm x 40

Ref Pdt 780013 5

U.C.



Ø 10 mm x 30

Ref Pdt 780014 2

### Assemblage de tablettes, panneaux, étagères

Assembling of shelves and panels  
Befestigung von Fachböden, Paneelen und Regalen  
Fijación de estantes y paneles





## Cubix «Assemblez vos idées»

Cubix «Assemble your ideas» • Cubix «Bauen Sie Ihre Ideen» • Cubix «monten vuestras ideas»

NOUVEAU

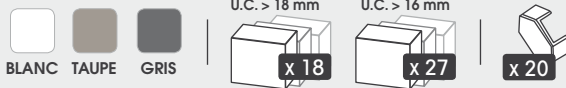
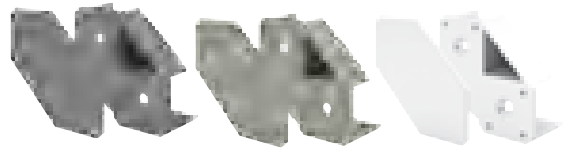

### Pour la création de meubles sur-mesure

To create tailor-made furniture  
Um ihre eigene spezifische Möbel zu erstellen  
Para la creación de muebles a medida



- ✓ Facile et rapide à mettre en œuvre
- ✓ Design et discret
- ✓ Économique
- ✓ Créer des meubles sur mesure
- ✓ Combinaisons à l'infini
- ✓ Look contemporain

Assembling ideas • Montieren Sie Ihre Ideen • Ensamble sus ideas

Made-to-measure furniture by you • Für Möbelbau nach Maß • Para crear muebles a medida

Quick and easy to install • Unkomplizierte und schnelle Montage • Sencillo y rápido de montar

Discreet and stylish • Diskretes Design • Discreto y de diseño

Economical • Kostensparend • Económico

Create made-to-measure furniture • Möbelbau nach Maß • Cree muebles a medida

Infinite combinations • Unendlich viele Kombinationen • Infinitas combinaciones

Contemporary look • Moderner Look • Estilo contemporáneo

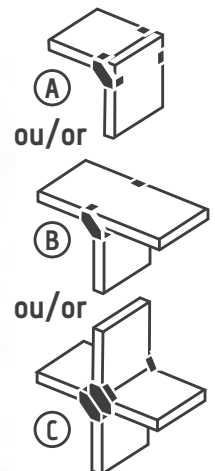

		Ref Pdt
16 mm	Blanc	3700536897637
	Taupe	3700536897651
	Gris	3700536897644
18 mm	Blanc	3700536897606
	Taupe	3700536897620
	Gris	3700536897613

144 cm (height)

122 cm (height)

36 cm (width)

37 cm (width)

23.5 cm (depth)

37 cm (width)

35 cm (depth)

46.5 cm (height)

**BIEN VU**

Le flashcode sur la boîte permet d'accéder au site [cubix.life](http://cubix.life) et à la vidéo de démo.

Ref Pdt 940151 4





## Jonc de rotin

Rattan • Rohrstück • Junco

u.c.



L. 1,70 m

Ref Pdt 890500 6

u.c.



L. 1,70 m

Ref Pdt 890600 3



## Rouleau de cannage

Canework roll • Rohgeflecht rohr • Rollo de rejilla

u.c.



l. 0,45 m L. 0,5 m

Ref Pdt 890003 2

u.c.



l. 0,61 m L. 1 m

Ref Pdt 890000 1

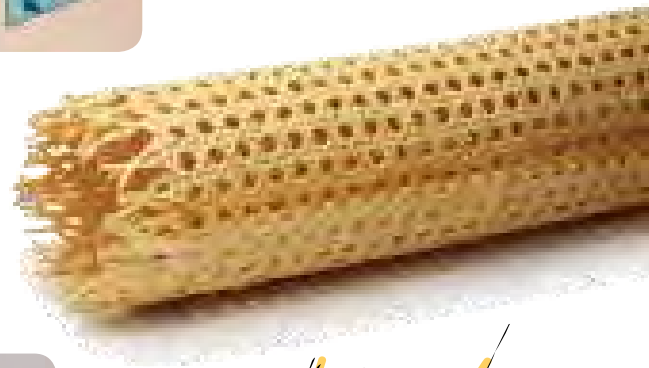
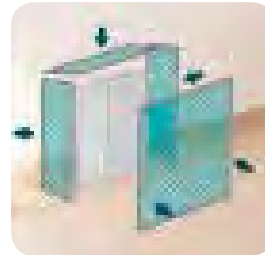

- ✓ **Qualité siège**
- ✓ **Résistant au poids**

Seat quality • Weight resistant • Qualität Sitz

Unempfindlich gegen Gewicht

Calidad de silla • Resistente al peso

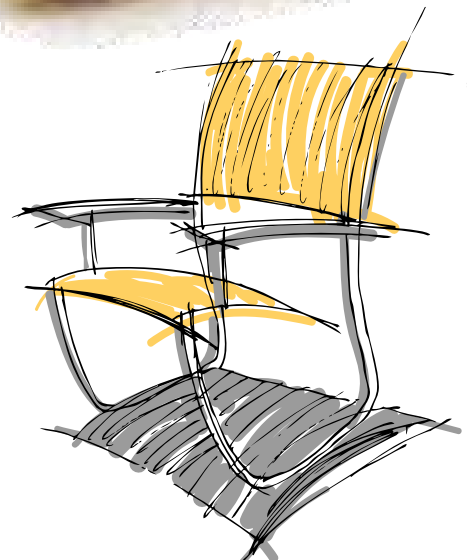



## Bande anti-dérapante

Anti-slip tape • Antirutschband  
Cinta antideslizante

U.C.



L. 6 ml l. 25 mm

- Bande auto-adhésive
- Pour marches d'escalier

Adhesive tape • Klebeband • Cinta adhesiva  
For stairs • Für Treppen • Para escaleras

Ref Pdt 742025 8



### ✓ Sécurise l'escalier

Makes stairs safer • Macht Treppen sicherer  
Hace las escaleras más seguras

## Lattes de sommier

Springing lath • Bettlatten • Lamas de somier

U.C.



Ep. 8 mm



l.	38 mm	53 mm	63 mm
Largueur du lit / Bed width / Bettbreite • Ancho de cama	Ref Pdt		
70 cm		(A) 741000 6	-
90 cm	(C) 741004 4	(B) 741001 3	(E) 740003 8
140 cm		(D) 741006 8	-

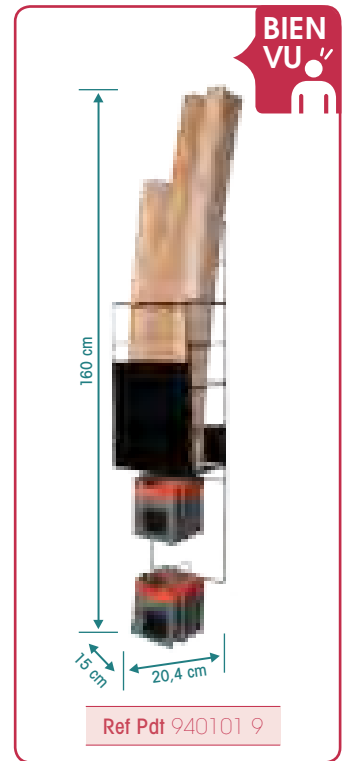

Ref Pdt 940101 9

## Embouts de latte plastique

Plastic tips • Plastik Kappen • Topes de plastico



U.C.



Ep. 8 mm

①

②

③

④

⑤

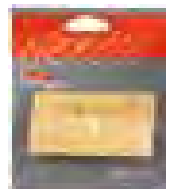

l.	38 mm	53 mm	63 mm
	Ref Pdt		
À clouer / To nail • Zum Annageln • Para clavar	① -	741002 0	-
	② -	-	740004 5
À clipser / To brooch • Zum Anklemmen • Con clips	③ -	741003 7	-
	④ -	-	741013 6
Double à clipser / Doppel to brooch • Doble Zum Anklemmen • Con clips	⑤ 741005 1	-	-





## Tréteau Essentiel H

**NOIR** | U.C. x 4 | x 2 | **300 kg Maxi** pour 2 tréteaux | 2,87 kg net

- Matériau : métal
- Pieds démontables avec rangement intégré dans le cadre du tréteau

Removable legs with integrated storage in the trestle frame • Abnehmbare Beine mit integriertem Stauraum im Bockrahmen • Patas desmontables con almacenamiento integrado en el marco del caballete

↑ 75 cm ← 75 cm ↗ 50 cm  
↓ 50 cm ← 75 cm ↘ 2,5 cm

Ref Pdt 640022 0

- ✓ Transport et rangement facilités
- ✓ Gain de place
- ✓ Pieds démontables sans outil
- ✓ Installation et démontage rapides
- ✓ Stabilité
- ✓ Extrémités tubulaires bouchées

Easy transport and storage • Einfache Transport und Lagerung • Transporte y almacenamiento fáciles - Save space • Spart Platz • Ahorra espacio - Removable legs without tools • Abnehmbare FüÙe ohne Werkzeug • Patas desmontables sin herramientas - Quick installation and release • schnelle Montage und Demontage • Instalación y desmontaje rápidos - Stable • Stabil • Estable - All tube ends with caps • Alle Rohrenden mit Kapfen • Todos los extremos de los tubos con tapas.

## Tréteau Helsinki

**NOIR** | U.C. x 4 | x 2 | **300 kg Maxi** pour 2 tréteaux | 2,87 kg net

- Matériau : métal
- Réglable en hauteur
- Pieds démontables avec rangement intégré dans le cadre du tréteau

Removable legs with integrated storage in the trestle frame • Abnehmbare Beine mit integriertem Stauraum im Bockrahmen • Patas desmontables con almacenamiento integrado en el marco del caballete

↑ 78 - 108 cm ← 75 cm ↗ 50 cm  
↓ ?? cm ← 75 cm ↘ 2,5 cm

Ref Pdt 640027 5

- ✓ Transport et rangement facilités
- ✓ Gain de place
- ✓ Pieds démontables sans outil
- ✓ Réglable en hauteur
- ✓ Installation et démontage rapides
- ✓ Stabilité
- ✓ Extrémités tubulaires bouchées

Easy transport and storage • Einfache Transport und Lagerung • Transporte y almacenamiento fáciles - Save space • Spart Platz • Ahorra espacio - Removable legs without tools • Abnehmbare FüÙe ohne Werkzeug • Patas desmontables sin herramientas - Adjustable height • Höhenverstellbar • Altura ajustable - Quick installation and release • schnelle Montage und Demontage • Instalación y desmontaje rápidos - Stable • Stabil • Estable - All tube ends with caps • Alle Rohrenden mit Kapfen • Todos los extremos de los tubos con tapas.

## Tréteau Promalin métal

**JAUNE** | U.C. x 4 | x 2 | **350 kg Maxi** pour 2 tréteaux | 3,95 kg net

- Matériau : Métal
- Revêtement antidérapant sur la traverse supérieure
- Poignée plastique épaisse et souple

Plastic handle, thick and flexible  
Kunststoffgriff, dick und flexibel  
Mango de plástico grueso y flexible

Ref Pdt 640025 1

↑ 78 cm ← 100 cm ↗ 50 cm  
↓ 6,5 cm ← 100 cm ↘ 10 cm

- ✓ Facile à plier et à transporter
- ✓ Pieds pliables avec rangement intégré dans le cadre du tréteau
- ✓ Traverse supérieure large pour plus de confort à l'usage

Easy to fold and carry • Leicht zu falten und zu tragen • Fácil de plegar y llevar - Removable legs with integrated storage in the trestle frame • Abnehmbare Beine mit integriertem Stauraum im Bockrahmen • Patas desmontables con almacenamiento integrado en el marco del caballete - Wide top bar for comfort in use • Breite Leiste oben für Komfort im Einsatz • Base superior ancha para mayor comodidad en uso.

## Tréteau PRO kit

**NOIR** | U.C. x 4 | x 1 | **300 kg Maxi** pour 2 tréteaux | 5,30 kg net

- Matériau : métal
- Tréteau professionnel réglable en hauteur
- Charge lourde

Ref Pdt 640023 7

1 seul mouvement

↑ 79 cm à 120 cm ← 75 cm ↗ 57 cm  
↓ 84 cm ← 75 cm ↘ 9 cm

- ✓ Robuste
- ✓ Réglable en hauteur
- ✓ Pliable pour être peu encombrant
- ✓ Rapport qualité/prix exceptionnel
- ✓ Ouverture et blocage simplifiés en un seul mouvement

Strong • Robust • Robusto - Adjustable height • Höhenverstellbar • Altura ajustable - Foldable therefore takes up little space • Faltpbar nimmt daher wenig Platz • Plegable, por lo tanto ocupa poco espacio - Exceptional price / quality ratio • Außergewöhnliches Preis / Leistungsverhältnis • Relación calidad / precio excepcional - Simplified implementation in one movement • Vereinfachte Umsetzung in einer Bewegung • Aplicación simplificada con un solo movimiento.



Déplié Unfolded  
Aufgeklappt • Abierto



Plié Folded  
Gefaltet • Plegado



## Tréteau Classic +



Ref Pdt 640021 3

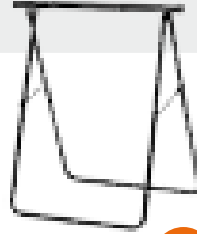

- ✓ Excellent rapport qualité/prix
- ✓ Système de compas innovant pour une sécurité accrue
- ✓ Qualité renforcée : épaisseur du compas et diamètre du tube
- ✓ Pliable pour être peu encombrant

Excellent price / quality ratio • Sehr gutes Preis / Leistungsverhältnis • Excelente relación calidad / precio. Compass system for added security • Compass-System für zusätzliche Sicherheit • Sistema de compas para mayor seguridad - Enhanced-Quality: hinge thickness and tube diameter • Verbesserte Qualität: Scharnierdicke und Rohrdurchmesser • Calidad mejorada: espesor de la bisagra y diámetro del tubo - Foldable therefore takes up little space • Faltbar nimmt daher wenig Platz • Plegable, por lo tanto ocupa poco espacio.

## Artisan Galva



- Matériau : acier galvanisé
  - Réglable en hauteur
- Adjustable height • Höhenverstellbar  
Altura ajustable

Ref Pdt 640024 4

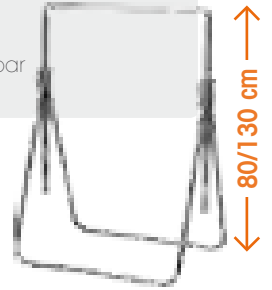
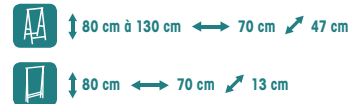

- ✓ De type pro/apptitude chantier
- ✓ Robuste
- ✓ Pliable pour être peu encombrant

Professional type. For construction sites • Profi-Ausführung. Für Baustellen • Tipo profesional. Para obras de construcción - Robust and durable • Robust und langlebig • Robusto y duradero - Foldable therefore takes up little space • Faltbar nimmt daher wenig Platz • Plegable, por lo tanto ocupa poco espacio.

## Tréteau plastipro \*



Ref Pdt 640026 8



- ✓ Ultra simple et rapide à monter
- ✓ Facile à plier, à transporter et à ranger
- ✓ De type pro/apptitude chantier
- ✓ Supporte une forte charge
- ✓ Robuste et durable
- ✓ Concept novateur ouvrant la gamme à de nouveaux matériaux

Very simple and quick assembly • Sehr einfache und schnelle Montage • Muy sencilla y rápido de montar - Easy to fold, carry and store • Leicht zu falten, zu transportieren und zu speichern • Fácil de plegar, de transportar y almacenar - Professional type. For construction sites • Profi-Ausführung. Für Baustellen • Tipo profesional. Para obras de construcción - Carries a heavy load • Trägt eine schwere Last • Soporta una carga pesada - Robust and durable • Robust und langlebig • Robusto y duradero - Innovative concept. Opens the range to new materials • Innovatives Konzept. Bietet der Kollektion neue Materialien an • Concepto innovador. Abre la gama a nuevos materiales.

## Tréteaux Hévéa

Rubberwood Trestle • Hevea-Holzbock  
Hevea hout schraag



H.	80 mm	75 mm	80 mm
l.	50 mm	75 mm	80 mm
u.c.	x 27	x 32	x 33

	Ref Pdt		
Taurus (section 20 x 45 mm)	640001 5	-	640000 8
First (section 20 x 35 mm)	-	640020 6	-



\* Jusqu'à épuisement du stock



Déplié Unfolded  
Aufgeklappt Abierto



Plié Folded  
Gefaltet Plegado



## Fermetures bois extensibles pour animaux

Extensible wood gates for animals  
Ausziehbar-holzgitter Holz für Tieren  
Cierres extensibles madera para animales



u.c. x 5



**Inadaptées aux enfants**

Not adapted to children • Passt nicht für Kindern  
No aptos para niños

NOUVEAU

**Stop'fix xx Tall**  
Pivotante  
Pivoting Holzgitter  
Pivotante

**Stop'fix**  
Pivotante  
Pivoting Holzgitter  
Pivotante

**Stop'Max**  
Pivotante  
Pivoting Holzgitter  
Pivotante

**Press'fix**  
À pression  
Pressure  
Drückgitter  
A presión

<b>H.</b>	120 cm	83 cm		
<b>l.</b>	60 / 200 cm	60 / 110 cm	60 / 230 cm	65 / 107 cm

Décor	Ref Pdt			
Blanc White • Weiss • Blanco	-	742001 2	-	-
Bois Wood • Holz • Madera	742051 7	742000 5	742011 1	742004 3

Existe aussi en hauteur 120 cm



Stop'fix



Stop'Max



Press'fix



### Mini box fermetures animaux

Mini Box display for animal gates

Mini Box für Tiergitter

Mini Box de vallas para animales

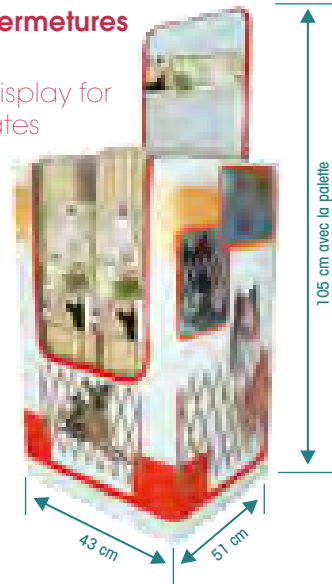

BIEN VU

	Stop'fix	Stop'Max	Press'fix
UNIT	x 40	x 25	x 30
Ref Pdt	940071 5		



## SÉCURITÉ

### BARRIÈRES DE SÉCURITÉ ENFANTS

## Barrières de sécurité enfants pivotantes

Pivoting children safety gates

Schwenkbare Kindersicherheitsgittern

Pivotante vallas de seguridad para niños



Bois  
Wood  
Holz  
Madera

Pivotante



● Métal Metal • Metall

Fixation avec perçage

With drilling • Zum Schrauben • Con perforación

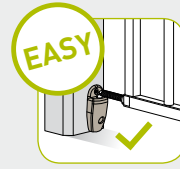
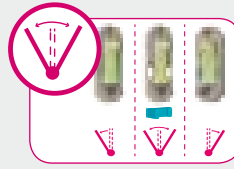

### Vogue

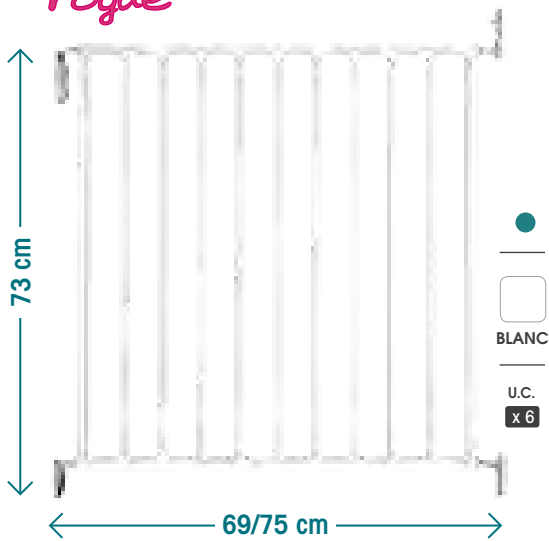

Ref Pdt	742029 6
Kit quincaillerie Hardware ki • Kleisenwaren • Kit fijaciones	630061 2

### Victoria

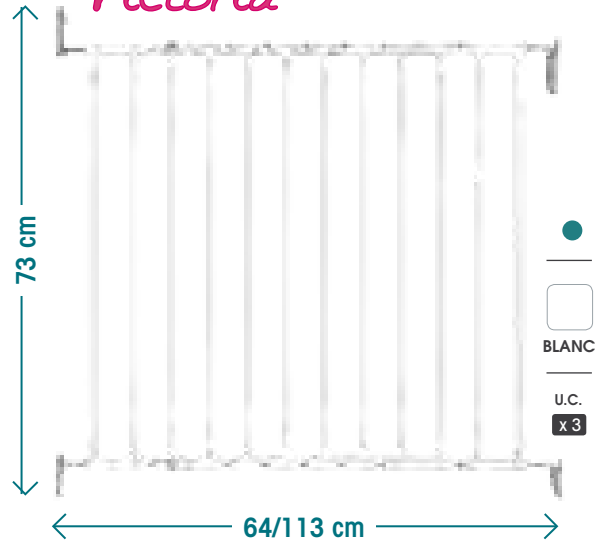

Ref Pdt	742028 9
Kit quincaillerie Hardware ki • Kleisenwaren • Kit fijaciones	630060 5



### Prune



Ref Pdt	742030 2
Kit quincaillerie Hardware ki • Kleisenwaren • Kit fijaciones	630062 9



## SÉCURITÉ

### BARRIÈRES DE SÉCURITÉ ENFANTS

## Barrières de sécurité enfants amovibles

Pull & hold children safety gates

Ziehen & halten  
kindersicherheitsgittern

Elevar & quitar vallas de  
seguridad para niños



Bois  
Wood  
Holz  
Madera

Amovible



À pression

Pressure mounted • Zum Drücken • Presión

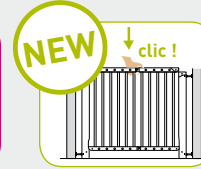
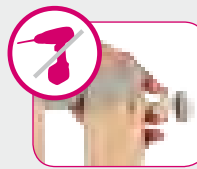
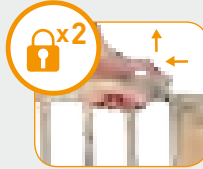

### Lila



Ref Pdt	630053 7
Kit quincaillerie Hardware ki • Kleisenwaren • Kit fijaciones	630064 3



### Oléane 7



Ref Pdt	630049 0
Kit quincaillerie Hardware ki • Kleisenwaren • Kit fijaciones	630063 6

### Oléane 8



Ref Pdt	630050 6
Kit quincaillerie Hardware ki • Kleisenwaren • Kit fijaciones	630063 6



## SÉCURITÉ

### BARRIÈRES DE SÉCURITÉ ENFANTS

## Barrières de sécurité enfants portillons

Central Gate children safety gates • Zentrale Tür kindersicherheitsgittern • Puerta Central vallas de seguridad para niños



● Métal  
Metal  
Metall

À pression

Pressure mounted • Zum Drücken • Presión



### Aalto



BLANC  
U.C. x3

### Sofia

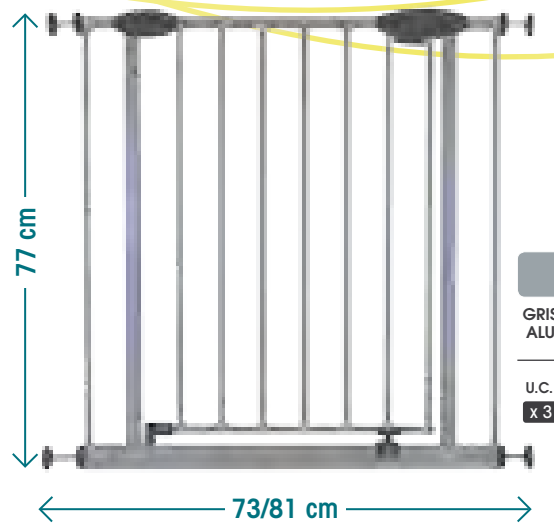

GRIS ALU  
U.C. x3

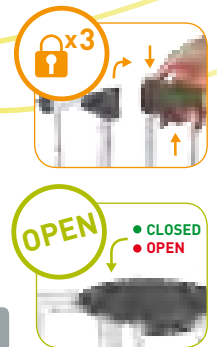

<b>Ref Pdt</b>	630045 2	
<b>Kit quincaillerie</b> Hardware ki • Kleisenwaren • Kit fijaciones	630052 0	
<b>Extension blanc</b> Extensions • Erweiterung • Extension	Extension A 8 cm	630046 9
	Extension B 16 cm	630047 6
	Extension C 20 cm	630048 3

<b>Ref Pdt</b>	630051 3	
<b>Kit quincaillerie</b> Hardware ki • Kleisenwaren • Kit fijaciones	630065 0	
<b>Extension gris alu</b> Extensions • Erweiterung • Extension	Extension A 8 cm	630054 4
	Extension D 16 cm	630055 1
	Extension E 20 cm	630056 8

## Besoin d'aide?

Flashez le code ci-contre pour accéder au guide d'aide au choix de la barrière.



## Extensions

Extension • Erweiterung • extensión

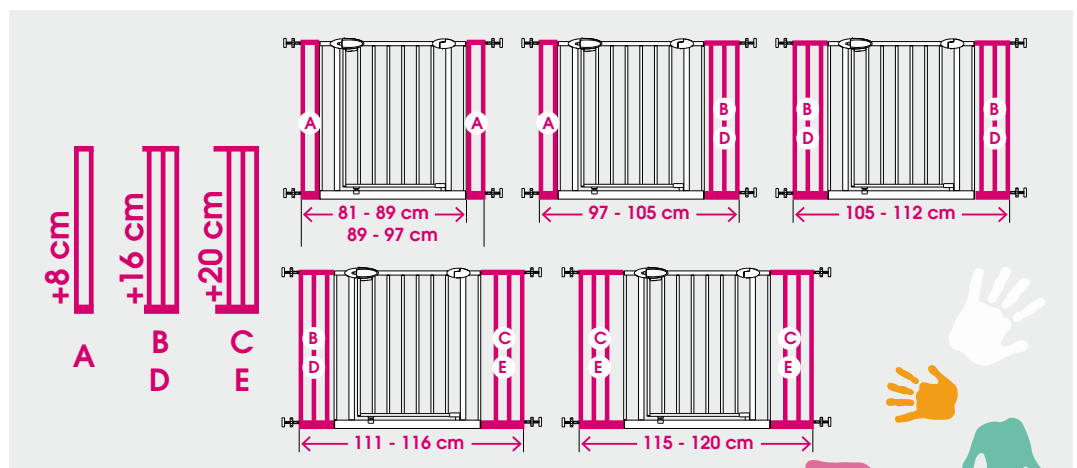



## Barrière pare feu / multifonctions

Fire guard gate • Kaminschutzgitter • Valla cortafuego



NOIR

H. 75 cm L. 73 - 370 cm



x 6 pans

u.c. x1

Ref Pdt 742022 7

Conforme aux  
exigences de sécurité



## Pour protéger l'enfant à la maison

To protect children at home  
Um die Kindern ins Hause Schützen  
Para proteger los niños en la vivienda

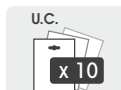

Ref Pdt

- |   |   |          |
|---|---|----------|
| 1 | <b>Cale-porte anti-dérapant</b><br>Non-slip door wedge • Rutschsicherer Türkeil<br>Calzo puerta antidelizante                                       | 742012 8 |
| 2 | <b>Loquet souple multi-surfaces</b><br>Multi surface flexible latch • Flexibler Riegel für alle<br>Oberfläche • Pestillo flexible multi-superficies | 742015 9 |
| 3 | <b>Protection coins de table</b><br>Protection for table corners • Schützung für Tafelecken<br>Protege-esquinas de mesa                             | 742013 5 |
| 4 | <b>Bloque-porte en mousse</b><br>Rubber foam door block • Türblockierungssystem<br>Bloqueo puerta espuma  | 742014 2 |

1

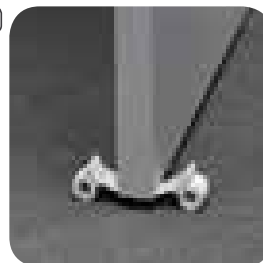

2



3



4







SÉCURITÉ  
SÉCURITÉ DOMESTIQUE

## Barrière de lit

Bedguard • Bettgitter  
Valla de cama

	H. 40 cm L. 91 cm
	u.c. x 5
	

Ref Pdt 742026 5



Existe aussi en longueur 122 cm  
en bois naturel et blanc

## Adaptateur pour escalier

To close staircases • Om trappen te sluiten • Para cerrar escaleras

	x 2		u.c.			Ref Pdt 742021 0
---	-----	---	------	---	---	------------------

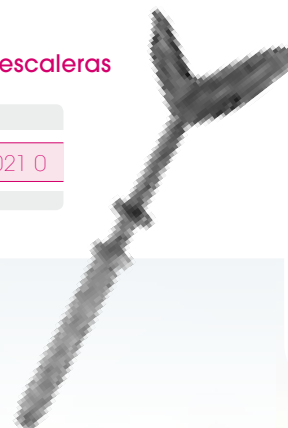





# Aides à la vente

Sales helps • Verkaufshilfen • Soportes de venta

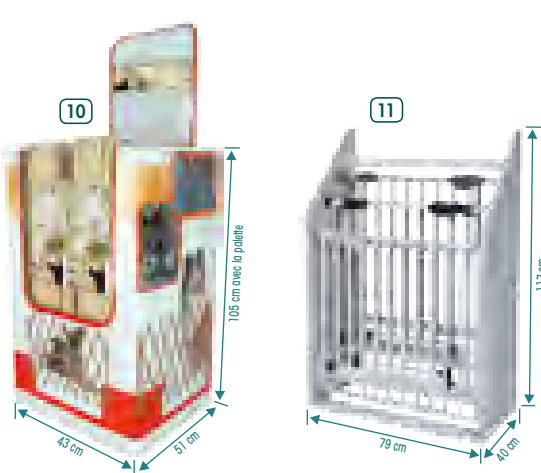

	CAPACITY	Ep. x l. x L.	Ref Pdt
1 Cross filaire 6 broches 6 Hooks display unit • 6 Brochen Präsenter Expositor 6 pinchos Cross filaire 6 broches + ILV thermo (skin chant) Cross filaire 6 broches + ILV adh. (skin chant)	42	20 x 5,5 x 125 cm	940068 5
	48		
2 Dévidoir vertical G.M. Display X.L. • Präsenter X.L. • Expositor X.L. Dévidoir vertical G.M. + ILV thermo Dévidoir vertical G.M. + ILV adh. Dévidoir vertical G.M. + ILV mastiplast	96	20 x 17 x 112 cm	940019 7
3 Broches dévidoir D + G		35 x 10 x 8 cm	940004 3
4 Cross skin fix	6	2,1 x 1,5 x 30 cm	970020 4
5 Présentoir 8 broches 8 Hooks display unit 8 Brochen • Expositor 8 pinchos		30 x 42 x 48 cm	940003 6
6 Présentoir filaire clips (boîtes clips)	22	10 x 22 x 92 cm	970016 2
7 Présentoir filaire lattes (lattes) (embouts de lattes) (placflex) (cannage) (profilis alu)	30	20,4 x 15 x 153 cm	940072 2
	10		
	6		
	6		
	60		
8 Cross filaire 4 broches Cross filaire 4 broches + ILV taquets (skin taquet)	24	20 x 5,5 x 127 cm	940105 7
9 Box "clips" : 3mm (250) 3mm (100) autres	250	51 x 43 x 105 cm	940005 0
	500		
	175		
10 Mini box fermetures animaux (press fix) (stop fix) (stop max)	30	43 x 51 x 105 cm	940071 5
	40		
	25		
11 Présentoir escalier "barrières"	4	79 x 40 x 117 cm	940110 1
12 Mini box barrière enfants		75 x 60 x 90 cm	940070 8
13 Présentoir plinthes	240	89 x 70 x 237 cm	940155 2
14 Présentoir plaque composite	50	86 x 50 x 150 cm	940157 6



## Aides à la vente

Sales helps • Verkaufshilfen • Soportes de venta

### Les stickers

	l. x H.	Ref Pdt
Sticker Placfix		940053 1
Sticker Profplast	17 x 25 cm	940050 0
Sticker Mastiplast		940020 3
Sticker Meladhesiv'		940067 8
Sticker Melafix	17 x 25 cm	940066 1
Sticker Prof'Alu		940028 9
Sticker Placflex		940104 0
Sticker Profil XSC - XSB	17 x 25 cm	940107 1
Sticker Clips		940029 6
Plinthes plastique	17 x 25 cm	940132 3
	9 x 30 cm	940133 0
Sticker Lattes pour filaire		940073 9
Sticker Taquets	17 x 25 cm	940102 6
Sticker Rapid'Fix		940103 3
Barrière de lit	30 x 10 cm	940032 6
Stop'Max	30 x 10 cm	940079 1
Press'Fix	30 x 10 cm	940080 7
Stop'Fix		940081 4
Placflex	30 x 30 cm	940122 4
Plaque Composite Alu	10 x 30 cm	940152 1
ILV pread		940135 4
ILV cannage	17 x 25 cm	940136 1
ILV Profil U Transparent		940137 8
Pread Carré	17 x 25 cm	940135 4
Profil Finition de Crédence		940139 2
Barrière Aalto	10 x 30 cm	910159 0
Barrière Lila		910160 6
Barrière Oléane 7		910161 3
Barrière Oléane 8		910162 0
Barrière Prune		910163 7
Barrière Sofia		910164 4
Barrière Victor		910165 1
Barrière Victoria		910166 8
Barrière Vogue		910167 5

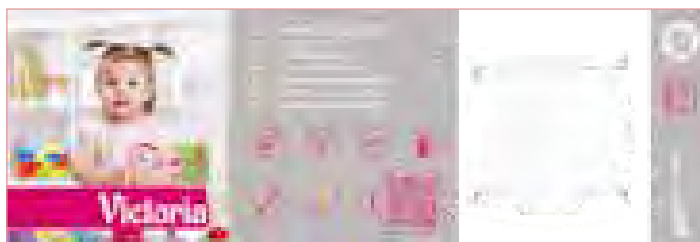
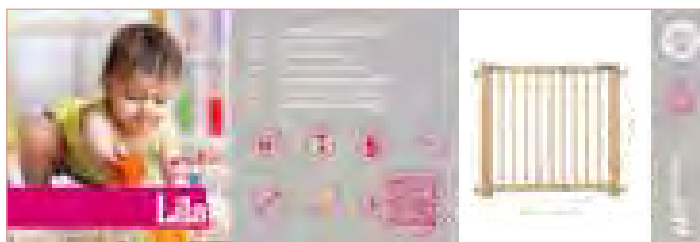
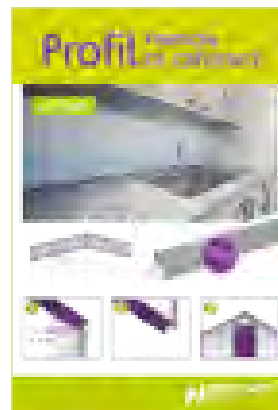
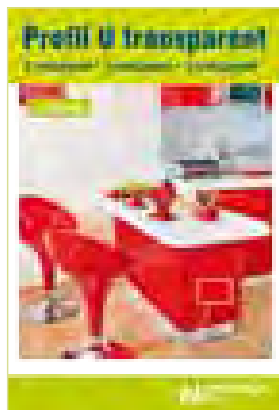

### Mini box barrières de sécurité enfants

Mini box display for baby safety gates

Mini box für kinder sicherheitsgitter

Mini box de vallas de seguridad para niños



	Victoria	Vogue	Prune	Oléane 7	Lila	Aalto	Sofia
CAPACITY	x 18	x 30	x 15	x 15	x 12	x 12	x 12
Ref Pdt	940158 3						

### Les nuanciers

The colour schemes

Die Farben • Los muestrarios

Les nuanciers	Ep.	Ref Pdt
Melanor	0,3 mm	940022 7
Nordex	0,8 mm	940023 4
Nordex	2 mm	940024 1
Bois Rolchant	-	970025 8
Alese	-	940027 2
QSapin	-	940026 5
Méla miné grandes largeurs	-	940141 5

# Conditions générales de vente

## Terms and conditions of sale / Allgemeine Geschäftsbedingungen • Condiciones Generales de Venta

### Acceptation des conditions générales de vente

Le fait de passer commande implique l'adhésion entière et sans réserve de l'acheteur aux conditions générales de vente ci-après énoncées. Ces conditions prévalent sur les conditions générales d'achat de l'acheteur. Toute contradiction ou particularité sera dorénavant d'acceptation, sauf avis contraire par écrit au vendeur, lequel sera sans effet et sans réserve de l'acheteur aux conditions générales de vente ci-après énoncées.

### Commandes

Toute commande doit être confirmée par écrit ou EDI par l'acheteur et ne peut donner dès lors lieu à contestation. Elle doit comporter coordonnées de l'acheteur, les références produits de NORDLINGER PRO, les quantités de produits commandés, la date de livraison souhaitée, le lieu de livraison, l'adresse de facturation. Nous disposons de toute liberté de décider de ne pas donner suite aux commandes passées et ce, notamment en regard :

- des délais impartis
- des quantités de produits
- des minima de commandes
- des stocks de produits détenus par NORDLINGER PRO, ce dernier faisant part à l'acheteur, lors du traitement de la commande, de ses possibilités.

Le bénéfice de la commande est personnel à l'acheteur et ne peut être cédé sans son accord préalable et écrit du vendeur.

### Tarif et gamme

Les factures sont établies au tarif et aux conditions en vigueur au moment de l'enregistrement de la commande. Toute commande qui nous est confirmée par écrit ou EDI ne peut donner lieu à contestation. Nos prix s'entendent nets hors taxes départ usine, TVA et tous autres frais annexés en sus. Les renseignements portés sur les catalogues, brochures ou autres documents techniques, ne sont donnés qu'à titre d'information et sans engagement. Nous nous réservons les fluctuations du marché (matériau, main d'œuvre, etc.) pour modifier nos prix, nos délais de livraison et nos réserves le droit de modifier à tout moment, notre gamme, notre tarif et nos conditions générales de vente. Aucune escompte n'est accordé au cas de règlement anticipé.

Nous prions s'entendre nous réservons de modifications, de toutes contributions ou taxes rendues obligatoires par la réglementation (en particulier l'article 137 de la loi n° 2007-08-27 du code de l'environnement, liée à la participation aux coûts d'élimination des éléments d'aménagement).

### Purpose and Application

The placing of an order represents the buyer's complete and unqualified acceptance of the terms and conditions of sale set out below.

These conditions have priority over the buyer's terms and conditions of purchase. No contrary special condition has priority over these terms and conditions of sale, regardless of the time such condition was made known, unless expressly accepted by NORDLINGER PRO.

### Orders

The buyer must confirm each order in writing or through electronic data interchange (EDI). Therefore the order is considered binding. The order must show the buyer's details, the quantity of products and their NORDLINGER PRO prices and the desired date of delivery, the place of delivery, and the billing address. NORDLINGER PRO reserves the right to refuse an order on, for example, the following grounds:

- deadline
- quantity
- minimum order
- stock

NORDLINGER PRO shall, while processing the order, inform the buyer of its capacity to fulfil the order. The terms and conditions of each order are specific to the buyer with whom they are agreed and may be transferred to any third party without NORDLINGER PRO's prior written agreement.

### Prices and Range

NORDLINGER PRO invoices in accordance with the prices and the conditions in force at the time the order is made. Any order confirmed in writing and delivered by postal service, fax or EDI cannot be disputed. NORDLINGER PRO reserves the right to change prices and ex-factory, any other costs, including VAT or carriage, are additional and shall be invoiced accordingly. Prices, colours and technical specifications of the products are subject to market fluctuations (in particular but not exclusively concerning raw materials and ex-factory). We reserve the right to modify without notice its range, prices and terms and conditions of sale. No discount shall be given for the early settlement of an invoice. NORDLINGER PRO reserves the right to modify its price, its range, its conditions of the creation or the modification of any contribution or tax made compulsory by the authorities, in particular the contribution, required under article 1345-247 of France's environmental code, to the cost of

### Annahme der Allgemeinen Geschäftsbedingungen

Mit seiner Bestellung nimmt der Käufer die folgenden Allgemeinen Geschäftsbedingungen vollumfänglich und ohne Einschränkung an.

Diese Bedingungen haben gegenüber den Allgemeinen Geschäftsbedingungen des Käufers Vorrang. Jede abweichende oder besondere Bedingung ist als vom Verkäufer gegenüber unanwendbar, ungeachtet des Zeitpunkts, wo sie von diesem zur Kenntnis genommen hätte werden können.

### Bestellungen

Jede Bestellung ist vom Käufer schriftlich oder per EDI zu bestätigen und ist ab diesem Moment verbindlich. Die Bestellung ist somit fest und verbindlich. Die Anzahl der Bestellungen ist die Anzahl der Produktereferenzen von NORDLINGER PRO, die Anzahl der bestellten Produkte, das gewünschte Lieferdatum, die Lieferanschrift und die Rechnungsanschrift. Wir können Bestellungen widersprechen, insbesondere aufgrund:

- der Fristen
- der Produktmenge
- des Mindestbestellwerts
- der Verfügbarkeit der Produkte
- der Mindestbestellwerts

• der Fristen- der Produktmenge
- des Mindestbestellwerts
- der Verfügbarkeit der Produkte
- der Mindestbestellwerts

Unsere Preise und unsere Allgemeinen Geschäftsbedingungen werden mit Ihnen mitgeteilt. Wir behalten uns das Recht vor, unser Sortiment, unsere Preise und unsere Allgemeinen Geschäftsbedingungen jederzeit zu ändern. Wir behalten uns das Recht vor, unsere Allgemeinen Geschäftsbedingungen jederzeit zu ändern. Wir behalten uns das Recht vor, unsere Allgemeinen Geschäftsbedingungen jederzeit zu ändern. Wir behalten uns das Recht vor, unsere Allgemeinen Geschäftsbedingungen jederzeit zu ändern.

### Preise und Sortiment

Die Rechnungen werden zu den bei der Registrierung des Auftrags durch uns geltenden Preisen und Bedingungen ausgestellt. Alle Bestellungen, die uns per Post, Fax oder EDI bestätigt werden, sind verbindlich. Unsere Preise verstehen sich netto vor Steuern ab Werk, zuzüglich Mehrwertsteuer und aller zusätzlichen Kosten, wozu auch die Transportkosten für den Käufer gehören. Wir behalten uns das Recht vor, unsere Preise, unsere Farb- oder technische Spezifikationen diesen wegzulassen (Information und sind unverbindlich). Aufgrund von Marktfluktuationen (insbesondere hinsichtlich Rohmaterial und Ex-fabrik) behalten wir uns das Recht vor, unser Sortiment, unsere Preise und unsere Allgemeinen Geschäftsbedingungen jederzeit zu ändern. Wir behalten uns das Recht vor, unsere Allgemeinen Geschäftsbedingungen jederzeit zu ändern. Wir behalten uns das Recht vor, unsere Allgemeinen Geschäftsbedingungen jederzeit zu ändern.

### Aceptación de las Condiciones Generales de Venta

El hecho de hacer un pedido implica la adhesión íntegra y sin reserva del comprador a las Condiciones Generales de Venta que se enuncian más abajo.

Dichas Condiciones prevalecen sobre las Condiciones Generales de Venta del comprador. Toda contradicción o particularidad será dorénavant de aceptación, salvo aviso contrario por escrito al vendedor, el cual será sin efecto y sin reserva de l'acheteur aux conditions générales de vente ci-après énoncées.

### Pedidos

Todo pedido deberá confirmarse por escrito o IED (intercambio electrónico de datos) por el comprador y desde ese momento instante no resultará impugnativo. Toda orden que sea confirmada por escrito o EDI no podrá dar lugar a contestación. Los precios de los productos y las condiciones de venta serán específicos para el comprador con quien se acuerden y podrán ser transferidos a cualquier tercero sin el consentimiento previo y por escrito del vendedor.

### Tarifa y gama

Las facturas se emitirán según la tarifa y las condiciones vigentes en el momento de registro del pedido por nuestra parte. Todo pedido que se nos confirme por correo electrónico, fax o IED no podrá ser disputado. NORDLINGER PRO reserva el derecho de modificar sin previo aviso su gama, precios y condiciones de venta. No se concederá descuento alguno en el supuesto de pago por adelantado. Cabe entender nuestros precios sin perjuicio de cualesquiera creaciones, modificaciones, de todas contribuciones o impuestos que sean obligatorios (en especial la contribución prevista en el artículo R. 543-247 del Código Ambiental francés, vinculada a la participación en

### Transport et délai de livraison

Le fait de passer commande implique l'adhésion entière et sans réserve de l'acheteur aux conditions générales de vente ci-après énoncées. Ces conditions prévalent sur les conditions générales d'achat de l'acheteur. Toute contradiction ou particularité sera dorénavant d'acceptation, sauf avis contraire par écrit au vendeur, lequel sera sans effet et sans réserve de l'acheteur aux conditions générales de vente ci-après énoncées.

### Disponibilité des produits

Sans prévisions détaillées du plan d'achat annuel pour tous nos articles, nous ne pouvons être tenus pour responsables d'un jour de service insuffisant. Nous recommandons expressément à l'acheteur de nous communiquer les volumes prévus pour les prochains mois, et ce, notamment en regard des commandes promotionnelles, 3 mois avant les premières commandes. Les produits en phase de lancement, sont historique, et en l'absence de volumes prévus, nous ne pouvons être tenus pour responsables d'un jour de service insuffisant. Nous recommandons expressément à l'acheteur de nous communiquer les volumes prévus pour les prochains mois, et ce, notamment en regard des commandes promotionnelles, 3 mois avant les premières commandes. Les produits en phase de lancement, sont historique, et en l'absence de volumes prévus, nous ne pouvons être tenus pour responsables d'un jour de service insuffisant. Nous recommandons expressément à l'acheteur de nous communiquer les volumes prévus pour les prochains mois, et ce, notamment en regard des commandes promotionnelles, 3 mois avant les premières commandes. Les produits en phase de lancement, sont historique, et en l'absence de volumes prévus, nous ne pouvons être tenus pour responsables d'un jour de service insuffisant.

Reclamation et retour marchandise

Reclamation et retour marchandise

Reclamation et retour marchandise

Reclamation et retour marchandise

Reclamation et retour marchandise

Reclamation et retour marchandise

Reclamation et retour marchandise

Reclamation et retour marchandise

Reclamation et retour marchandise

Reclamation et retour marchandise

Reclamation et retour marchandise

Reclamation et retour marchandise

Reclamation et retour marchandise

Reclamation et retour marchandise

Reclamation et retour marchandise

Reclamation et retour marchandise

Reclamation et retour marchandise

Reclamation et retour marchandise

Reclamation et retour marchandise

Reclamation et retour marchandise

Reclamation et retour marchandise

Reclamation et retour marchandise

Reclamation et retour marchandise

Reclamation et retour marchandise

Reclamation et retour marchandise

Reclamation et retour marchandise

Reclamation et retour marchandise

Reclamation et retour marchandise

Reclamation et retour marchandise

Reclamation et retour marchandise

Reclamation et retour marchandise

Reclamation et retour marchandise

Reclamation et retour marchandise

Reclamation et retour marchandise

dés) relative à disposition de la marchandise.

Les pénalités pré-déterminées pour l'acheteur requièrent une déduction et compensation de la somme de 40% du montant de la somme restant due au jour de la déduction.

Force majeure

Force majeure

Force majeure

Force majeure

Force majeure

Force majeure

Force majeure

Force majeure

Force majeure

Force majeure

Force majeure

Force majeure

Force majeure

Force majeure

Force majeure

Force majeure

Force majeure

Force majeure

Force majeure

Force majeure

Force majeure

Force majeure

Force majeure

Force majeure

Force majeure

Force majeure

Force majeure

Force majeure

Force majeure

Force majeure

Force majeure

Force majeure

Force majeure

Force majeure

Force majeure

Force majeure

Force majeure

Force majeure

Force majeure

Force majeure

Force majeure

Force majeure

Force majeure

Force majeure

Force majeure

Force majeure

Force majeure

Force majeure

Force majeure

Force majeure

Force majeure

Force majeure

Force majeure

Force majeure

Force majeure

Force majeure

Force majeure

Force majeure

Force majeure

Force majeure

Force majeure

Force majeure

Force majeure

Force majeure

Force majeure

Force majeure

Force majeure

Force majeure

Force majeure

Force majeure

Force majeure

Force majeure

Force majeure

Force majeure

Force majeure

Force majeure

Force majeure

Force majeure

Force majeure

Force majeure

Force majeure

Force majeure

Force majeure

Force majeure

Force majeure

Force majeure

Force majeure

Force majeure

Force majeure

Force majeure

Force majeure

Force majeure

Force majeure

Force majeure

Force majeure

Force majeure



**CONSULTEZ LE  
CATALOGUE OÙ QUE  
VOUS SOYEZ !**

Accédez depuis votre  
smartphone ou votre  
tablette numérique  
au catalogue à  
feuilleter sur internet.

[www.nordlinger-pro.com](http://www.nordlinger-pro.com)



[contact@nordlinger-pro.com](mailto:contact@nordlinger-pro.com)

CS n°20001 Vignolles • 16300 Barbezieux-Saint-Hilaire • France  
France tél : 05 45 78 19 99 • fax : 05 45 78 28 80  
International tél : 0033 545 787 957 • fax : 0033 545 782 880

N°TVA : FR83 485310262 / RCS Angoulême : 485310262 / SIRET : 48531026200012  
© Crédits photos : iStock - Fotolia : Photographmd - Ostap25 - Shutterstock - Freepik  
Mickaël Tollemer. Conception © Maia [www.maia-creation.com](http://www.maia-creation.com)