



Votre partenaire pour
l'agencement de l'habitat

Your partner for home improvement
Ihr partner für die gestaltung des lebensraums
Su socio para el acondicionamiento de la vivienda



Plus de 80 ans d'expérience ont permis à la société Nordlinger Pro de devenir leader dans le domaine des bandes de chants et des solutions d'amélioration de l'habitat.



Vos administratrices des ventes

Export : Mélissa
+ 33 5 45 78 79 57



Mélissa
05 45 78 79 57

14/16/17/18/22/23/27/
28/29/35/36/37/41/44/
45/49/50/52/53/56/61/
72/76/79/85/86/95



Gaëlle
05 45 78 79 71

01/03/04/05/07/08/10/
21/25/26/38/39/42/43/
51/52/54/57/58/63/67/
68/69/70/71/73/74/77/
84/88/89/90



Marie
05 45 78 33 04

06/09/11/12/13//15/19/20/24/30/31/
32/33/34/40/46/47/48/64/65/66/81/
82/83/87/02/59/60/62/75/77/78/80/
91/92/93/94/95/ANDORRE/MONACO

- Barrières de sécurité enfants
- Barrières de lit
- Accessoires de sécurité domestique

SÉCURITÉ p 36



ACCESSOIRES & OUTILLAGE p 22

- Systèmes d'assemblage
- Cannage
- Anti-dérappant lattes & embouts
- Tréteaux
- Fermetures extensibles pour animaux



AIDES À LA VENTE p 42 CONDITIONS GÉNÉRALES DE VENTE p 43



SOL & MUR p 27

- Cales pour parquet
- Plinthe cache'fil
- Clips à lambris et accessoires

- Bandes de chant mélaminées
- Bandes de chant bois véritable
- Bandes de chant CPL
- Araseurs de chant
- Concordances décors panneaux
- Placage bois
- Revêtement adhésif
- Plaque composite
- Profils plastiques



PANNEAUX p 6



CUISINE p 12

- Profilés pour crédence et plan de travail
- Étanchéité de crédence et plan de travail
- Accessoires pour plinthes
- Accessoires pour meubles de cuisine

Les dimensions figurant dans ce catalogue sont indicatives et peuvent accepter de légères variations. Documents et photographies non contractuels.

The dimensions stated in this catalogue are for information only and are subject to slight variations. Documents and photographs are not contractual. Die Abmessungen in diesem Katalog sind unverbindlich und können geringfügige Abweichungen zu akzeptieren. Dokumente und Fotos sind nicht vertraglich. Las dimensiones de este catálogo son indicativas y pueden aceptar ligeras variaciones. Documentos y fotografías no contractuales

Pour tous les produits : Gencod = 3 35476 XXXXXX X (ref pdt)

- H.** Hauteur
Height • Höhe • Altura
- l.** Largeur
Width • Breite • Ancho
- L.** Longueur
Length • Länge • Longitud
- Ep.** Épaisseur
Thickness • Dicke • Espesor
- UC.** Unité de commande
Order unit • Bestelleinheit
Unidad de pedido



Sachet cavalier Plastic bag with header • Plastikbeutel mit Header
Bolsa de plástico con cabecera



Skin-pack
Skin Pack • Skin Pack • Skin Pack



Boite
Box • Box • Caja



Fourreau
Sleeve • Schlauch • Tubo



Rouleau
Roll • Rolle • Rollo



Chant : film plastique Plastic film
Plastiktasche • Bolsa de plástico



Chant : vrac Bulk
Unverpackt • A granel



Barrière : film plastique Plastic film
Plastiktasche • Bolsa de plástico

CONCEPTION

Une équipe « Recherche & Développement » de 5 personnes pour concevoir et mettre au point des solutions techniques innovantes, pour gagner en performance et faciliter la mise en œuvre.

A 5 person R & D team to design and develop innovative and technical solutions to improve performance and make implementation easier • Ein R & D Team von 5 Personen, das innovative technische Lösungen entwirft und entwickelt, um sie effizient und einfach zu implementieren • Un equipo de I + D de 5 personas para diseñar y desarrollar soluciones técnicas innovadoras para mejorar el rendimiento y facilitar su aplicación.



FABRICATION



Une parfaite maîtrise de la chaîne de fabrication grâce à une expertise industrielle de 60 ans.

Perfect control of the production line thanks to an industrial expertise of more than 60 years • Eine perfekt kontrollierte Produktionslinie dank eines industriellen Know-hows von mehr als 60 Jahren • Perfecto control de la línea de producción gracias a una experiencia industrial de más de 60 años.

MARKETING



Une approche marketing au service de votre stratégie :

- des gammes efficaces vous garantissant une couverture optimale de vos marchés,
- des services et des outils d'aide à la vente dédiés pour dynamiser vos ventes,
- une compétitivité de tous les instants.

A marketing approach to serve your strategy : effective ranges guaranteeing optimal coverage of your markets - dedicated services to boost your sales - competitiveness at all times • Ein Marketing-Ansatz, um Ihre Strategie zu unterstützen: effektive Kollektionen, die eine optimale Abdeckung Ihrer Märkte garantieren - spezielle Dienstleistungen, um Ihren Umsatz zu steigern - Wettbewerbsfähigkeit zu jeder Zeit • Un enfoque de marketing al servicio de su estrategia: colecciones eficaces para garantizar una cobertura óptima de sus mercados - servicios dedicados para aumentar sus ventas - competitividad en todo momento.

À VOTRE ÉCOUTE

Une organisation commerciale de 11 personnes à l'écoute de vos besoins et à vos côtés pour accélérer votre développement.

A commercial team of 11 people listening to your needs and by your side to accelerate your development • Ein kommerzielles Team von 11 Personen hört auf Ihre Bedürfnisse und beschleunigt an Ihrer Seite Ihre Entwicklung • Una organización comercial de 11 personas escuchando sus necesidades y a su lado para acelerar su desarrollo.



NORMES



Nos produits sont conçus, fabriqués et contrôlés dans un total respect des normes et exigences en vigueur selon un cahier des charges très strict répondant aux exigences des professionnels.

Our products are designed, manufactured and tested in full compliance with current standards according to strict specifications that meet the requirements of the trade • Unsere Produkte sind in voller Übereinstimmung mit den geltenden Normen entwickelt, gefertigt und geprüft, und unterliegen strengen Vorgaben, die den Anforderungen von Profis entsprechen • Nuestros productos están diseñados, fabricados y probados en plena conformidad con las normas vigentes y conforme a normativas estrictas que cumplan los requisitos de los profesionales.

LOGISTIQUE



Une logistique dédiée à nos clients dont l'excellence est reconnue depuis plus de 30 ans.

Dedicated logistics to customers whose excellence has been recognized for over 30 years • Spezielle Kundenlogistik, deren Exzellenz seit über 30 Jahren anerkannt ist • Logística dedicada a los clientes cuya excelencia ha sido reconocida por más de 30 años.

BY One

Les couleurs du négoce

NOUVEAU

GAMME CHANTS PLASTIQUES NON ENCOLLÉS

- ✓ Des concordances parfaites avec les plus grandes marques de panneaux.
- ✓ Consultez le module de recherche en ligne, simple, rapide et accessible à tout moment.

PFLIEDERER FORMICA POLYREY WODEGO
FINSA KRONO
EGGER KRONOSWISS RESOPAL KRONOSPAN
WODECO RESOPAL KRONOFRANCE THERMOPAL FINSA
RESOPAL UNILIN FORMICA



Votre bande de chant à partir de 1 mètre linéaire.



Bandes de chants disponibles en différentes épaisseurs (0.45 mm, 1 mm, 2 mm).



Une gamme complète, composée de 1000 décors au choix.



Différentes largeurs sont proposées, jusqu'à 66 mm.



Prestation découpe possible.



Prestation encollage possible sur simple demande.



Option Airtech et Lasertech sur demande, avec délai supplémentaire.



Tarif unique livraison.

UN PLAN DE SOUTIEN DYNAMIQUE

Offres quantitatives



Nuancier décors sur demande



Module de recherche de concordances en ligne





Bandes de chant mélaminées



Melamine edgings
Melamin Kantenumleimer
Cantos Melamínicos

Ep. ± 0,3 mm

Non Encollé (Mélanor)
non pre-glued
ohne
Schmelzkleber
sin cola

Pré Encollé (Mélafix)
pre-glued • mit Schmelzklebe
con cola

Auto-Adhésif (Méladhésif)
self-adhesive
selbstklebend • autoadhesivo



L.

23 mm

23 mm

16 mm

19 mm

L.

100 ml

5 ml

25 ml

50 ml

100 ml

5 ml

25 ml

5 ml

25 ml

Type	Code	Décor	Surface	Ref Pdt								
Brut	S B3	Beige Beige		141001 9	151001 6	151003 0	-	-	-	-	-	-
Blanc	L 001	Blanc à laquer White • weiss • blanco	L	061019 9	071023 3	074061 2	-	-	-	-	-	-
	P 099	Blanc White • weiss • blanco	L	061323 7	071029 5	074066 7	075457 2	075462 6	160007 6	160023 6	160001 4	160013 7
	P 099		G	061472 2	071257 2	074069 8	075493 0	075461 9	-	-	-	-
	P 150		L	061427 2	071024 0	074062 9	075513 5	075468 8	-	-	-	-
	P 150		G	061476 0	071306 7	074293 7	075590 6	075492 3	-	-	-	-
	P 268	Blanc brillant White • weiss • blanco	VB	060205 7	071025 7	074063 6	-	-	-	-	-	-
	S 5022	Blanc très brillant White • weiss • blanco	VTB	060218 7	070692 2	070694 6	-	070700 4	-	-	-	-
	P 099	Blanc pores frêne Ash • esche • fresno	PF	060092 3	071691 4	074390 3	075821 1	071620 4	-	-	-	-
Beige	P 119 ☒	Beige clair Beige	G	060119 7	074208 1	074072 8	074505 1	070359 4	-	-	-	-
	P 104 ☒	Seringa Syringa • seringa	L	061671 9	071026 4	074064 3	070113 2	075725 2	-	-	-	-
	P 104 ☒	Seringa Syringa • seringa	G	061598 9	071328 9	074224 1	075658 3	075744 3	-	-	-	-
Brun	S 0845	Brun taupe / Moka Moka	L	-	070516 1	-	-	-	-	-	-	-
	S 5182	Taupe L2201 Mole • Maulwurf • Topo	L	-	121829 5	-	-	-	-	-	-	-
Rouge	I 267 ☒	Rouge Red • rot • rojo	L	061651 1	071228 2	074338 5	075699 6	070366 2	-	-	-	-
	I 474 ☒	Rouge Red • rot • rojo	G	-	-	-	-	-	-	-	160106 6	-
Orange	I 446 ☒	Orange Orange • Orange • Naranja	G	-	-	-	-	-	-	-	160108 0	-
Vert	W 1600 ☒	Vert 285 U Green • Grün • Verde	L	-	070514 7	-	-	-	-	-	-	-
	I 491	Vert reinette Light Green • Grün • Verde claro	L	-	-	-	-	-	-	-	160109 7	-
Gris	P 121	Gris clair / Béton clair Grey • grau • gris	L	061560 6	071027 1	074065 0	070301 3	070361 7	-	-	160102 8 ☒	160131 8 ☒
	P 121	Gris clair / Béton clair Grey • grau • gris	G	061584 2	074446 7	074347 7	075657 6	075781 8	-	-	-	-
	I 296	Gris n°1 / Anthracite Grey • grau • gris	G	060060 2	070796 7	074408 5	075839 6	070367 9	-	-	160174 5	-
Noir	I 264	Noir Black • Schwarz • Negro	L	061582 8	071030 1	074076 6	071802 4	075546 3	160008 3	160019 9	160002 1	160016 8
	I 264	Noir Black • Schwarz • Negro	G	061474 6	071220 6	074283 8	075690 3	075534 0	-	-	-	-
	S 5021	Noir très brillant Black • Schwarz • Negro	VTB	060216 3	070693 9	070695 3	-	070698 4	-	-	-	-
	W 629 ☒	Noir pores frêne Black • Schwarz • Negro	PF	061553 8	071244 2	071247 3	075719 1	070357 0	-	-	-	-
Métal Minéral	I 442	Gris alu Alu		060131 9	070232 0	070451 5	070334 1	070375 4	160098 4	-	160113 4	-
	F 5000	Béton Concrete • Beton • Hormigón		-	070697 7	-	-	070743 1	-	-	-	-
	S 5140	Béton gris usé / Brossé Concrete • Beton • Hormigón		-	121749 6	-	-	-	-	-	-	-
	S 5138	Béton minéral / Griffé / OxiD 37 Concrete • Beton • Hormigón		-	121814 1	-	-	-	-	-	-	-
	S 5183	Béton clair SB Concrete • Beton • Hormigón		-	121828 8	-	-	-	-	-	-	-
Bois gris	W5010	Urban Urban		-	070752 3	-	-	-	-	-	-	-
	W 1857	Chêne grisé 860 Oak • Eiche • Roble		-	070669 4	070679 3	-	-	-	-	160138 7	-
	W 5011	Chêne scié 868 Oak • Eiche • Roble		-	070753 0	-	-	-	-	-	-	-
	S 5184	Gris agadir tissé F755 Grey • Grau • Gris		-	121830 1	-	-	-	-	-	-	-
	S 0804	Pin nouveaux grisé Pine grey • Grün • Pino gris		-	121812 7	-	-	-	-	-	-	-
Bois clair	F 429 ☒	Multiplex Multiplex	L	-	-	-	-	-	-	-	160114 1	160154 7
	W 1856	Frêne / Pin blanchi White pine • Kiefer • Pino blanco		060212 5	070670 0	070677 9	071446 0	070734 9	-	-	160139 4	160157 8
	W 1597	Planche blanc usé / Chêne blanchi antique		-	070802 5	070681 6	-	-	-	-	-	-
	W 5003 ☒	Chêne cèrusé blanchi Oak • Eiche • Roble		-	070691 5	070720 2	-	-	-	-	-	-
	W 1421	Bouleau / Érable Maple • Ahorn • Arce		061770 9	071400 2	074708 6	071816 1	070347 1	160020 5	-	160046 5	-
	W 5012	Acacia crème Ash • Esche • Fresno		-	070758 5	-	-	-	-	-	-	-
	W 5001 ☒	Chêne clair blanc Oak • Eiche • Roble		-	071821 5	070682 3	-	-	-	-	-	-
	W 706	Hêtre flamme / Érable Maple • Ahorn • Arce		060129 6	070417 1	070420 1	070322 8	070373 0	-	-	-	-
	W 316	Chêne naturel / nouveaux SB / Blanc 327 U Oak • Eiche • Roble		060130 2	070234 4	070419 5	070321 1	070374 7	160009 0	-	160003 8	160031 1



	Non Encollé (Mélanor) non pre-glued ohne Schmelzkleber sin cola	Pré Encollé (Mélafix) pre-glued • mit Schmelzklebe con cola				Auto-Adhésif (Méladhésif) self-adhesive selbstklebend • autoadhesivo			
L.	23 mm	23 mm				16 mm		19 mm	
L.	100 ml	5 ml	25 ml	50 ml	100 ml	5 ml	25 ml	5 ml	25 ml

Type	Code	Décor	Surface	Ref Pdt							
Bois clair	W 1634	Chêne nat clair 387 Oak • Eiche • Roble	-	070539 0	070678 6	-	070745 5	160175 2	-	160140 0	-
	W 1635	Chêne grenade / Canada / Acacia tabac Oak • Eiche • Roble	-	070540 6	070684 7	-	-	-	-	-	-
	W 602	Pin Pine • Kiefer • Pino	061606 1	071049 3	074098 8	075659 0	075740 5	160011 3	160130 1	160005 2	160033 5
	W 937	Hêtre Loire / 747 Beech • Buche • Haya	061676 4	071397 5	074694 2	071815 4	071492 7	160015 1	-	160014 4	160022 9
	W 080	Hêtre clair du jura Beech • Buche • Haya	060115 9	070033 3	071868 0	070100 2	070350 1	-	-	-	-
	W 522	Hêtre Beech • Buche • Haya	061603 0	071278 7	074292 0	075672 9	075785 6	160101 1	-	160100 4	-
	W 495	Pommier Apple-tree • Apfelbaum • Manzano	060066 4 *	070186 6 *	070185 9 *	070148 4 *	070372 3 *	160067 0 *	160085 4 *	160068 7	160088 5
	S 5037	Chêne du Québec / Dakota Oak • Eiche • Roble	-	121588 1	-	-	-	-	-	-	-
Bois brun	W 5018 *	Chêne modé Oak • Eiche • Roble	-	-	-	-	-	160143 1	-	-	-
	W 897	Noyer traîa Walnut • Nussbaum • Nogal	061612 2 *	071343 2 *	074552 5 *	071813 0 *	070346 4 *	-	-	160144 8	-
	W 108	Chêne nature Oak • Eiche • Roble	060108 1	070403 4	074688 1	071842 0	071687 7	-	-	-	-
	W 542	Chêne clair Oak • Eiche • Roble	061663 4	071044 8	074094 0	071812 3	075685 9	-	-	160176 9	-
	W 593	Chêne lamellé Oak • Eiche • Roble	060068 8	071054 7	074170 1	070084 5	070342 6	-	-	-	-
	W 933 *	Teck / Pin olvéga / Chêne Héléna Teck • Teak • Teca	061788 4	071801 7	071717 1	071741 6	071803 1	-	-	-	-
	W 211 *	Chêne clair sully Oak • Eiche • Roble	060055 8	070197 2	070193 4	070170 5	070175 0	-	-	-	-
	W 1615 *	Chêne héléna Oak • Eiche • Roble	-	070530 7	070680 9	-	-	-	-	-	-
	S 5107	Chêne authentique / Gris / H443 Colorado Oak • Eiche • Roble	-	121701 4	-	-	-	-	-	-	-
	S 5133	Chêne Bodega Oak • Eiche • Roble	-	121748 9	-	-	-	-	-	-	-
S 5181	Chêne tissé marron Oak • Eiche • Roble	-	121827 1	-	-	-	-	-	-	-	
Bois rouge	W 865 *	Merisier moyen Cherry • Kirsche • Cerezo	060112 8	071370 8	074658 4	071810 9	070220 7	-	-	-	-
	W 020	Merisier/Prunier foncé SB Cherry • Kirsche • Cerezo	060072 5	070057 9	071867 3	070099 9	070349 4	160012 0	-	160006 9	160021 2
	W 1637 *	Teck miel Teck • Teak • Teca	-	070536 9	070688 5	-	070736 3	-	-	-	-
	W 013	Acajou Mahogany • Mahogany • Caoba	060069 5	071874 1	071723 2	071744 7	070338 9	160048 9	-	160044 1	160126 4
Bois rustique	W 992	Vieux chêne Oak • Eiche • Roble	060054 1	070189 7	070267 2	070169 9	070174 3	-	-	-	-
	W 561 *	Chêne dauphine Oak • Eiche • Roble	061605 4	071226 8	074104 6	074508 2	075463 3	-	-	-	-
	W 611 *	Chêne des vosges Oak • Eiche • Roble	061697 9 *	071128 5 *	074109 1 *	070013 5 *	075485 5 *	160010 6	-	160004 5	160032 8
	W 5005 *	Noyer clair Walnut • Nussbaum • Nogal	-	070708 0	070733 2	-	-	-	-	-	-
	W 014 *	Noyer Walnut • Nussbaum • Nogal	-	070801 8	-	-	-	-	-	160103 5	-
Bois foncé	W 1411	Noyer américain Walnut • Nussbaum • Nogal	-	070491 1	-	-	-	-	-	-	-
	W 1638 *	Teck cognac Teck • Teak • Teca	-	070537 6	070687 8	-	-	-	-	160142 4	-
	W 1427 *	Makassar Makassar	-	070535 2	070685 4	-	-	-	-	-	-
	W 5000 *	Pin ottawa Pine • Kiefer • Pino	-	070671 7	070686 1	-	-	-	-	-	-
	W 1855	Chêne anthracite foncé wengé Oak • Eiche • Roble	-	070668 7	070683 0	-	-	160148 6 *	-	160137 0	-
		Planche noir usé Oak • Eiche • Roble	-	070799 8	-	-	-	-	-	-	-
	W 1572	Wengé / Noyer foncé Wengé	060132 6	070233 7	070270 2	070263 4	070376 1	160086 1	160104 2	160087 9	160127 1
	W 5013	Chêne foncé 436 Oak • Eiche • Roble	-	070794 3	-	-	-	-	-	-	-
	S 5172	Wengé Wengé	-	121798 4	-	-	-	-	-	-	-

L : Lisse Smooth • Glatte Oberfläche • Superficie lisa / G : Grainé Embossed • Perl Struktur • Poro soft
 PF : Pores frêne Ash embossing • Dekor Esche • Relieve fresno / VB : Verni brillant Glossy varnish • Glanzlack • Barniz brillo
 VTB : Verni très brillant High gloss varnish • Hochglanz-Lack • Barniz con mucho brillo
 * Jusqu'à épuisement du stock



Bandes de chant mélaminées > largeurs spéciales

Melamine edgings >
Special widths
Melamin Kantenumkleimer >
Spezielle Breiten
Cantos Melamínicos >
Anchos especiales



Ep. ± 0,3 mm



L.

Non Encollé
(Mélano)

non pre-glued
ohne Schmelzkleber
sin cola

Pré Encollé
(Mélafix)

pre-glued • mit Schmelzkleber
con cola



100 ml

1,32 ml

4,20 ml

5 ml

25 ml

100 ml

ℓ.	Type	Code	Décor	Surface	Ref Pdt							
20 mm	Blanc	P 099	Blanc White • weiss • blanco	L	061594 1	061003 8	-	-	071190 2	074193 0	075664 4	075012 3
		P 099		G	-	060105 0	-	-	070041 8	074287 6	-	075234 9
		P 150		L	-	061002 1	-	-	071004 2	074008 7	-	075013 0
		P 150		G	-	060136 4	-	-	-	070027 2	-	-
26 mm	Blanc	P 099	Blanc White • weiss • blanco	L	060076 3	061167 7	-	-	-	070423 2	070303 7	070035 7
		P 099		G	060093 0	061190 5	-	-	-	-	-	071547 4
		P 150		L	061564 4	061672 2	-	-	-	-	-	070238 2
		P 150		G	061785 3	060010 7	-	-	-	-	-	070217 7
34 mm	Blanc	P 099	Blanc / Super White • weiss • blanco	L	-	-	-	-	070797 4	-	-	-
	Brun	W 1601	Brun taupe Moka Moka	G	-	-	-	-	070750 9	-	-	-
		S 5107	Chêne authentique / Gris / H443 Colorado Oak • Eiche • Roble		-	-	-	-	121811 0	-	-	-
	Gris	P 121	Gris clair / Béton clair Grey • Grau • Gris	L	-	060232 3	-	-	070749 3	-	-	-
	Métal/Minéral	S 5138	Béton minéral / Griffé / Oxid 37 Concrete • Beton • Hormigon		-	-	-	-	121815 8	-	-	-
	Bois gris	S 0804	Pin nouveau grisé Pine grey • Grün • Pino gris		-	-	-	-	121813 4	-	-	-
	Bois clair	W 1597	Planche blanc usé / Ch blanchi / Antique Oak • Eiche • Roble		-	-	-	-	070798 1	-	-	-
		W 1634	Chêne nat clair 387 Oak • Eiche • Roble		-	-	-	-	070748 6	-	-	-
Bois foncé	W 1855	Planche noir usé / Chêne anthracite / Foncé Oak • Eiche • Roble		-	-	-	-	070800 1	-	-	-	
38 mm	Blanc	S 5022	Blanc très Brillant White • weiss • blanco	VTB	-	-	-	-	070710 3	-	-	-
	Noir	S 5021	Noir très brillant Black • Schwarz • Negro	VTB	-	-	-	-	070709 7	-	-	-
42 mm	Blanc	P 099	Blanc White • weiss • blanco	L	061575 0	061084 7	-	-	071172 8	074138 1	075653 8	075128 1
		P 099		G	-	061312 1	-	-	074550 1	074240 1	-	075447 3
		P 150		L	061566 8	061055 7	-	-	071093 6	074134 3	071473 6	075096 3
		P 150		G	-	065716 3	-	-	070020 3	075529 6	-	075203 5
		S 0840			Blanco White • Weiss • Blanco		-	-	121831 8	121832 5	-	-
	Beige	P 104	Seringa Syringa • Seringa	L	-	061782 2	-	-	071095 0	074136 7	-	075097 0
	Noir	I 264	Noir Black • Schwarz • Negro	L	060161 6	061263 6	-	-	071096 7	074139 8	-	075099 4
	Métal Minéral	I 442	Gris alu alu		-	060204 0	-	-	070523 9	070643 4	-	070723 3
		S 5140	Béton / Basalt Concrete • Beton • Hormigon		-	-	121810 3	121809 7	-	-	-	-
		S 5147	Ciment Cement • Mörtel • Cemento		-	-	121835 6	121836 3	-	-	-	-
		S 5145	Ardoise Slate • Schiefer • Pizarra		-	-	121837 0	121838 7	-	-	-	-
		F 408	Gris moucheté Grey marble • Grau • Gris		-	-	070804 9	070803 2	-	-	-	-
	Bois clair	W 1421	Bouleau / Érable Maple • Ahorn • Arce		-	060104 3	-	-	070204 7	070292 4	-	-
		W 937	Hêtre Loire / 747 Beech • Buche • Haya		-	060159 3	-	-	070144 6	070299 3	-	070243 6
		W 522	Hêtre Beech • Buche • Haya		-	060080 0	-	-	070143 9	070427 0	-	070227 6
		W 495	Pommier Apple-tree • Apfelbaum • Manzano		-	-	-	-	070146 0	070507 9	-	-
	Bois brun	W 593	Chêne lamellé Oak • Eiche • Roble		-	-	-	-	070202 3	070241 2	-	070522 2
		S 5131	Lamello Oak • Eiche • Roble		-	-	121833 2	121834 9	-	-	-	-
	Bois rouge	W 020	Merisier / Prunier foncé SB Cherry • Kirsche • Cerezo		-	060197 5	-	-	070203 0	070424 9	-	-
Bois rustique	W 1165	Noyer K Walnut • Nussbaum • Nogal		-	-	-	-	070526 0	-	-	-	
Bois foncé	W 1572	Wengé / Noyer foncé Wenge		-	-	-	-	070524 6	070642 7	-	070655 7	
Bois gris	S 0804	Pin nouveau grisé Pine grey • Grün • Pino gris		-	-	121840 0	121839 4	-	-	-	-	

Bandes de chant bois véritable

Natural wood veneer edgings • Echtholz Furnier Kanten • Cantos de chapa de madera



	Non Encollé (Rolchant) non pre-glued ohne Schmelzkleber • sin cola	Pré Encollé (Rolfix) pre-glued • mit Schmelzkleber • con cola			Non Encollé Épais (Alèse Bois) non pre-glued • ohne Schmelzkleber sin cola
Ep.	+/- 0,6 mm	+/- 0,6 mm			+/- 2 mm +/- 3 mm
ℓ.	23 mm	23 mm	40 mm	23 mm	24 mm
L.	100 ml	100 ml	20 ml	5 ml	50 ml

Esence	Ref Pdt						
Chêne Oak • Eiche • Roble	290502 6	260103 4	260503 2	260517 9	220702 1	250412 0	250142 6
Acajou Mahogany • Mahagoni • Caoba	290505 7	260100 3	260500 1	260507 0	220700 7	250000 9	-
Aniégré Anigre • Anegre • Mukaly	290506 4	260101 0	260541 4	-	220701 4	-	-
Châtaignier Chestnut-tree • Kastagnie • Castaño	290518 7	260102 7	260601 5	-	220029 9	-	-
Érable Maple • Ahorn • Arce	290314 5	260697 8	260708 1	-	220030 5	250039 9	-
Frêne Ash • Esche • Fresno	290500 2	260105 8	260504 9	260538 4	220703 8	250413 7	-
Hêtre Beech • Buche • Haya	290507 1	260106 5	260506 3	260539 1	220704 5	250298 0	-
Hêtre étuvé Beech • Buche • Haya	290000 7	260009 9	260013 6	-	220037 4	250327 7	-
Koto	290514 9	260107 2	260518 6	-	220705 2	-	-
Merisier Cherry • Kirsche • Cerezo	290504 0	260110 2	260523 0	260024 2	220707 6	250465 6	-
Noyer Walnut • Nussbaum • Nogal	290508 8	260111 9	260524 7	-	220708 3	250041 2	-
Okoumé Okoume • Okume	290510 1	260112 6	260519 3	260021 1	220710 6	-	-
Orme Elm • Ulme • Olmo	-	260113 3	260520 9	-	220709 0	-	-
Pin Pine • Kiefer • Pino	290503 3	260114 0	260505 6	260569 8	220711 3	250466 3	-
Poirier Pear • Birbaum • Peral	290056 4	290094 6	290069 4	-	-	-	-
Sapin Fir-tree • Tanne • Pino	290554 5	260143 0	260537 7	-	220815 8	-	-
Teck Teak • Teca	290517 0	260116 4	260521 6	260030 3	220714 4	250040 5	-
Wengé Wenge	290057 1	290073 1	290043 3	260059 4	-	-	-

Bandes de chant plastique NORDEX

Plastic Edgings • Plastische-Kantenumleimer • Cantos plásticos

		Non Encollé (Nordex) non pre-glued • ohne Schmelzkleber • sin cola										
Ep.	2 mm	0,8 mm	0,6 mm	0,45 mm	0,8 mm	0,6 mm	0,8 mm	2 mm	0,8 mm	0,8 mm		
ℓ.	23 mm				16 mm	26 mm			33 mm	45 mm		
L.	100 ml											
Décor	n° décors	Surface	Ref Pdt									
Blanc White • weiss • blanco	0 13265	L	011563 2	010052 2	011415 4	011406 2	010176 5	010109 3	010117 8	011605 9	010241 0	010243 4
	0 13265	G	011635 6	010053 9	011444 4	011286 0	-	010108 6	010118 5	010021 8	010242 7	010244 1

L : Lisse Smooth • Glatte Oberfläche • Superficie lisa / **G** : Grainé Embossed • Perl Struktur • Poro soft

VB : Verni brillant Glossy varnish • Glanzlack • Barniz brillo / **VTB** : Verni très brillant High gloss varnish • Hochglanz-Lack • Barniz con mucho brillo

***** Jusqu'à épuisement du stock

***** Disponible en 40 mm Available in 40 mm • Auch in 40 mm • Disponible en 40 mm



PANNEAU
Chant



Bandes de chant CPL (stratifiées)

CPL Edgings • CPL Kantenumleimer • Cantos CPL

Non Encollé non pre-glued ohne Schmelzkleber sin cola				
		l.	23 mm	
		L.	100 ml	
Type	Code	Décor	Surface	Ref Pdt
Blanc	P 099	Blanc White • weiss • blanco	L	120036 8
			G	120025 2

Pré Encollé pre-glued mit Schmelzklebe con cola				
		l.	42 mm	
		L.	4,2 ml	
Type	Code	Décor	Surface	Ref Pdt
Métal Minéral	S 5138	Béton griffé Concrete • Beton • Hormigon		121819 6
	S 5187	Inox brossé alliage Stainless steel • Rostfreier Stahl • Acero inoxidable		121823 3
	S 5188	Caldera Mineral light • Mineral licht • Mineral claro		121821 9
	S 5189	Trieste Mineral dark • Mineral dunkel • Mineral oscuro		121825 7
Bois	S 5037	Chêne du québec Oak • Eiche • Roble		121592 8
	S 5106	Chêne bastide Oak • Eiche • Roble		121593 5
	S 5107 ☒	Chêne des marais Oak • Eiche • Roble		121594 2
	S 5120	Chêne topia Oak • Eiche • Roble		121817 2
Textile	S 5108 ☒	Textus poivre Grey - Grau - Gris		121595 9
	S 5109 ☒	Textus gris Grey - Grau - Gris		121596 6



Araseurs de chant

Edge banding trimmer • Kantenhobel • Refilador

Pour une meilleure finition des chants des supports de type aggloméré, MDF, contreplaqué

For a better edge finish on chipboard, MDF, plywood • Für eine bessere Fertigung der Kanten auf Spanplatten, MDF, Sperrholz • Para un mejor acabado de los cantos sobre aglomerado, MDF, contrachapado

Araseur simple

Single sided edge trimmer
Kantenhobel • Refilador simple



Araseur simple
Single sided edge trimmer
Kantenhobel • Refilador simple

Ref Pdt 650100 2



3 lames
Blades • Klingen • Cuchillas

Ref Pdt 650200 9



✓ **Lame réversible**
Reversible blade
Kombiklingen
Cuchilla reversible



Araseur double

Double sided edge trimmer • Doppel-Klingen-Kantenhobel Refilador doble

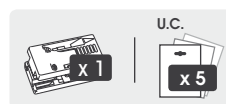

Araseur double Double sided edge trimmer • Doppel-Klingen-Kantenhobel • Refilador doble

Ref Pdt 650400 3



6 lames
Blades • Klingen • Cuchillas

Ref Pdt 650500 0



✓ **Pour l'arasement en même temps des deux côtés**
To level simultaneously on both sides • Für die Nivellierung auf beiden Seiten gleichzeitig
• Para la nivelación simultáneamente en ambos lados











Gamme Polyrey / Nordlinger. Bandes de chant mélaminées CPL (stratifiées)

Encollées et non-encollées en +/- 0,35 mm

En partenariat avec POLYREY, nous avons élaboré la gamme chants correspondant aux références de la gamme PANOPREY® 2017.

 Collection 2017 • 156 Complémentaires					
Décor Panneau PANOPREY® - Panneau Mélangé Polyrey		Pré encollé pre-glued • mit Schmelzklebe con cola l. 23 mm L. 25 ml 	Non Encollé non pre-glued • ohne Schmelzkleber sin cola l. 23 mm L. 150 ml 	Décor Bande de Chant	
Code	Décor	Ref Pdt Npro	Ref Pdt Npro	Coloris	Finition
005	Noir classique	121293	130130	N005	Satin
030	Blanco especial	121275	130112	B070	
149	Gris paloma	121600	130411	0149	
156	Crème classique	121290	130127	C017	
A014	Aiguë marine	121281	130118	A014	Satin
A022	Acajou de floride	121324	130161	A022	
A036	Amandine	121348	130187	A036	
A057	Aulne naturel	121277	130114	A057	
A103	Argile sablée	121628	130439	A103	Mat
B001	Bleu flash	121344	130181	B001	Satin
B014	Blanc avoriaz	121289	130126	B014	
B015	Blanc menuires	121275	130112	B070	
B023	Bois de pécan	121349	130188	B023	
B031	Borneo naturel	121602	130413	B031	Satin
B048	Bleu oslo	121309	130146	B048	
B068	Blanc chamonix	121275	130112	B070	
B069	Blanc courchevel	121282	130119	B069	
B070	Blanc megève	121275	130112	B070	Satin
B086	Bleu caraïbes	121283	130120	B086	
B092	Brossé gris	121311	130148	B092	
B094	Brushed copper	121630	130441	B094	
B099	Brushed métal	121631	130442	B099	Satin
B100	Banjan blanchi	121236	130073	B100	
B101	Banjan noirci	121241	130078	B101	
B102	Bouleau de sibérie	121604	130415	B102	
B116	Beige nature	121641	130452	B116	Satin
B117	Blanc artic	121282	130119	B069	
B118	Bleu nuit	121642	130453	B118	
B119	Bleu turquoise	121643	130454	B119	
B120	Brique	121644	130455	B120	Satin
B131	Bouleau argenté	121603	130414	B131	
B134	Béton griffé	121629	130440	B134	
C003	Chêne de macédoine	121607	130418	C003	
C004	Charme d'amboise	121267	130104	C004	Satin
C014	Chêne cérusé	121321	130158	C014	
C017	Coquille d'œuf	121290	130127	C017	
C026	Coco foncé	121665	130476	C026	
C047	Chêne wengé	121339	130176	T020	Satin
C062	Capucine	121243	130080	C062	
C091	Chêne de fil brun	121339	130176	T020	
C092	Chêne de compiègne	121607	130418	C003	
C098	Chêne de fil naturel	121291	130128	C098	Satin
C101	Chêne brun horizontal	121244	130081	C101	
C102	Chêne clair horizontal	121245	130082	C102	



Décor Panneau PANOPREY® Panneau Mélangé Polyrey 		Pré encollé pre-glued • mit Schmelzklebe con cola l. 23 mm L. 25 ml 	Non Encollé non pre-glued • ohne Schmelzkleber sin cola l. 23 mm L. 150 ml 	Décor Bande de Chant		
Code	Décor	Ref Pdt Npro	Ref Pdt Npro	Coloris	Finition	
C103	Chêne lavé	121284	130121	C103	Satin	
C104	Cœur de pommier	121613	130424	C104		
C105	Chêne quebec	121457	130302	C105	Mat	
C116	Chocolat	121648	130459	C116	Satin	
C117	Citronnelle	121649	130460	C117		
C118	Cèdre bleu	121647	130458	C118		
C119	Cassis	121646	130457	C119		
C120	Caramel	121645	130456	C120		
C127	Chêne giverny	121609	130420	C127	Satin	
C128	Chêne alaska	121664	130475	C128	Mat	
C129	Chêne bastide	121625	130436	0081		
C130	Chêne topia	121611	130422	C130	Satin	
C131	Chêne murano	121610	130421	C131		
C132	Chêne des marais	121608	130419	C132		
C133	Chêne vendôme	121612	130423	C133		
C134	Chêne brocante	121608	130419	C132		
C137	Chêne cut naturel	121605	130416	C137	Satin	
C138	Chêne cut wengé	121606	130417	C138		
D018	Chêne de meymac	121292	130129	D018	Satin	
D021	Pommier de deauville	121307	130144	D021		
E009	Érable blanc	121268	130105	E009	Satin	
E021	Écru	121345	130182	E021		
E025	Érable wengé	121237	130074	E025		
E028	Érable nordique	121314	130151	E028	Satin	
F001	Florida	121355	130194	F001		
F006	Fer	121305	130142	F006		
F008	Fumée	121651	130462	F008		
F011	Fruittier ambré	121315	130152	F011		
F012	Fruittier cendré	121269	130106	F012	Mat	
F013	Fruittier naturel	121318	130155	H025	Satin	
F026	Feutre	121278	130115	F026		
F053	Fleur d'anis	121650	130461	F053		
F056	Frêne scandinave	121626	130437	0083		
F058	Frêne cristal	121614	130425	F058		
F061	Frêne montréalaise	121626	130437	0083	Satin	
G003	Gris perle	121316	130153	G003		
G012	Grès	121235	130072	G012	Satin	
G024	Grenade	121459	130293	G024		
G029	Gris tourterelle	121601	130412	G029		
G031	Genêt	121356	130195	G031		
G044	Gris dauphin	121276	130113	G044		
G059	Gris orange	121285	130122	G059	Satin	
G075	Gris cendré	121653	130464	G075		
G076	Gris acier	121652	130463	G076		
H001	Hêtre domancy	121609	130420	C127	Satin	
H025	Pommier de honfleur	121318	130155	H025		
H026	Hêtre horizontal	121616	130427	H027		
H027	Hêtre de provence	121616	130427	H027		
H028	Hêtre bergen	121615	130426	H028		
H029	Hêtre stockholm	121618	130429	H029	Satin	
H031	Hêtre rouvre	121617	130428	H031		
J018	Jaune gouache	121249	130086	J018	Satin	
K001	Kiwi	121358	130197	K001		
L067	Lilas	121654	130465	L067		
M001	Maryland clair	121632	130443	M001		Satin
M003	Maryland foncé	121633	130444	M003		



Décor Panneau PANOPREY® Panneau Mélangé Polyrey		polyrey <small>A WILSONART COMPANY</small>		Pré encollé pre-glued • mit Schmelzklebe con cola	Non Encollé non pre-glued • ohne Schmelzkleber sin cola	Décor Bande de Chant		
		l. 23 mm L. 25 ml		l. 23 mm L. 150 ml				
Code	Décor	Ref Pdt Npro	Ref Pdt Npro	Coloris	Finition			
M007	Merisier rustique	121619	130430	M007	Satin			
M090	Merisier clair	121292	130129	D018				
M091	Merisier ambré	121319	130156	M091				
M100	Muscade	121655	130466	M100	Satin			
M105	Merisier horizontal	121666	130477	M105				
M106	Mosaïc blanc	121634	130445	M106				
M107	Mosaïc gris	121635	130446	M107	Satin			
N002	Néon	121656	130467	N002				
N003	Noyer du périgord	121333	130170	N010				
N005	Noir	121293	130130	N005	Satin			
N010	Noyer perlé	121333	130170	N010				
N024	Noyer tropical	121454	130299	T025				
N026	Noyer ombré	121253	130090	N026	Satin			
N027	Noyer vénitien	121254	130091	N027				
N056	Noisetier naturel	121621	130432	N056				
N057	Noisetier brun	121620	130431	N057	Mat			
O030	Olivier de séville	121255	130092	O030				
O077	Orchidée	121657	130468	O077		Satin		
O078	Orme de nancy	121624	130435	O078				
O079	Orme armagnac	121622	130433	O079				
O081	Orme des flandres	121625	130436	O081	Mat			
O082	Orme d'autrefois	121623	130434	O082				
O083	Orme lubéron	121626	130437	O083		Satin		
P001	Pierre de lune	121287	130124	P001				
P009	Poirier de corréze	121338	130175	P009	Satin			
P039	Poirier des flandres	121329	130166	P039				
P067	Poirier naturel	121368	130221	P067		Satin		
P092	Pomme verte	121298	130135	P092				
P112	Prune	121658	130469	P112	Satin			
P115	Palmier brun horizontal	121667	130478	P115				
P118	Pin argent	121614	130425	F058				
P119	Pin moka	121627	130438	P119	Mat			
P120	Pierre de lave	121636	130447	P120				
R021	Rose tendre	121362	130201	R021		Satin		
R036	Rouge cerise	121299	130136	R036				
R044	Rose dragée	121660	130471	R044				
R045	Rose pivoine	121661	130472	R045	Mat			
R049	Rouille	121637	130448	R049				
S040	Cérusé clair	121301	130138	S040		Satin		
S066	Sable mouillé	121662	130473	S066				
T006	Tectonica	121638	130449	T006	Mat			
T020	Toraja wood	121339	130176	T020		Satin		
T025	Teck massif	121454	130299	T025				
T051	Tulipier fumé	121262	130099	T051	Satin			
T052	Tulipier tabac	121263	130100	T052				
T063	Terre d'ombre	121663	130474	T063		Mat		
T086	Textus gris	121639	130450	T086				
T087	Textus poivre	121640	130451	T087	Satin			
V011	Vert d'eau	121455	130300	V011				
V014	Vinyle	121265	130102	V014		Satin		
Y022	Rose bougainvillée	121659	130470	Y022				
Z002	Zebra moka	121304	130141	Z002	Satin			
Z008	Zebrano naturel	121337	130174	Z008				
Z009	Zebrano ambré	121266	130103	Z009				
Z021	Zeste citron vert	121668	130479	Z021				
Z023	Zeste orange	121669	130480	Z023				



PANNEAU
Chant



Concordances Egger Formica-Unilin Krono

Correspondence
Übereinstimmung
Correlacion



Chants
mélaminés
Melamine edgings
Melamin
Kantenumleimer
Cantos Melamínicos

Pré encollé
pre-glued
mit
Schmelzklebe
con cola
L. 23 mm
L. 25 ml

EGGER

Décor panneau

Code	Décor	Ref Pdt
W908 SM	Blanc craie	075317
W908 ST2		074458
W980 SM	Blanc kaolin	075317
W980 ST2		074458
U708 ST15	Gris clair	074380
U763 ST15	Gris perle	-
U999 ST2	Noir	074385
F509 ST2	Aluminium	070327
F583 ST2	Filigène brun	-
H3332 ST10	Chêne nebraska gris	121763
H3734 ST9	Noyer de bourgogne naturel	070791
H1887 ST9	Érable de starnberg	-
H1733 ST9	Bouleau de maineau	-
H1615 ST9	Merisier romana	-
H3128 ST15	Merano naturel	-
H3031 ST9	Olivier de cordoue foncé	121793
H3025 ST15	Makassar	070792
H3704 ST15	Noyer aïda naturel	-
H1334 ST9	Chêne de ferrare clair	-
H3389 ST11	Chêne naturel clair	074419
H1502 ST15	Aulne	-
H1582 ST15	Hêtre du tyrol	-
H1920 ST9	Hêtre de lyons naturel	070161
H1511 ST15	Hêtre de bavière	-
H1706 ST15	Merisier	-
H3113 ST15	Poirier de lindau	-
H1951 ST15	Calvados sardeine	-
U999 ST11	Noir	074675
U999 ST30		070788
H078 ST79	Hêtre dosse	-
H806 ST9	Chêne anthracite transversal	070793

Chants
mélaminés
Melamine edgings
Melamin
Kantenumleimer
Cantos Melamínicos

Pré encollé
pre-glued
mit
Schmelzklebe
con cola
L. 23 mm
L. 25 ml

FORMICA UNILIN

Décor panneau

Code	Décor	Ref Pdt
F7949 Mat / W13 CST	Soft white	074458
F8761 Mat / UD72 CST	Jasmina	121765
F8760 Mat / UD59 CST	Creamy	121758
F8733 Mat / U127 CST	Dune beige	121756
F8751 Mat / U287 CST	Mojave	121780
F8750 Mat / U284 CST	Mokka	121785
F8757 Mat / U288 CST	Choco	121794
F8753 Mat / U282 CST	Fondant	121761
K3210 Mat / U279 CST	Levante	121796
F2962 Mat / U272 CST	Clementine	121767
F7845 Mat / U273 CST	Spectrum red	121789
F8752 Mat / U281 CST	Vino	121771
F0231 Mat / U268 CST	Peaceful blue	121753
F0232 Mat / U275 CST	Juicy pink	121790
F8754 Mat / U283 CST	Violetta	121762
F8755 Mat / U285 CST	Lemon	121787
F8763 Mat / UD96 CST	Silicon	075497
K2020 Mat / UD26 CST	Tornado	121774
K1097 Mat / U129 CST	Citadel	121768
F8762 Mat / UD81 CST	Quartz	121773
F2253 Mat / UD35 CST	Diamond black	074385
F8946 SMT / H720 BST	White birch	071632
F8940 Mat / H609 CST	Vichy pear	-
F8927 SMT / H339 BST	Solara oak	070326
F8936 SMT / H561 BST	Italian walnut	121783
F8939 Mat / H607 CST	Canadian walnut	-
F8929 Mat / H470 CST	Royal cherry	070060
F8935 Mat / H555 CST	Java walnut	121752
F8920 Mat / H304 CST	Patina oak	121791
F8971 SMT / H863 BST	Etna oak	121759
F8963 SMT / H349 BST	Urban oak	121760
F8924 SMT / H336 BST	Verona oak	070793
F8967 SMT / H892 BST	Logan oak	121792
F8765 Mat / F934 CST	Alu	070327

KRONOSPAN

Décor panneau

Code	Décor	Ref Pdt
K101 SM	Blanc faces	075336
K101 PE		075337
K100 SM		075336
K100 PE	Blanc edelweiss	075337
U109 BS	Coquille d'œuf	121765
U514 PE	Ivoire	070125
U522 SM	Beige	074480
U522 PE		070125
U112 SM	Gris	121772
U112 PE		075497
U162 PE	Graphite	074371
U106 PE	Blanc perle	074458
U1302 BS	Beige labo	121770
U119 PE	Beige hansa	121756
U179 PE	Gris caillou	-
U164 PE	Anthracite	121773
U190 PE	Noir	074385
U190 SM		074372
U190 SE		074675
U504 PE	Maïs	121758
U1301 PE	Vanille	121758
U2645 PE	Orange jaffa	121796
U148 PE	Rouge corail	121789
U2511 PE	Bordeaux	121771
U131 PE	Jaune	-
U2500 PE	Lipstick	121771
U2510 PE	Carafes	121753
U2512 PE	Havana	121794
D495 PE	Elysée	121777
D2566 PE	Twist	121795
D2813 VL	Ardoise	121788
D1309 WF	Aluminium	121754
D853 WF	Titan	121754
U191 PE	Gris clair	075497
D375 PE	Érable	070312
D2514 PE	Woodstock	121766
D7935 PE	Prunier wallis	121781
D2813 PE	Ardoise	121788
D2520 PE	Split	121788
D2210 VL	Cœur de hêtre	-
D1489 BS	Érable blanc	-
D1783 BS	Mangfall	075891
D2533 NA	Érable gotland	071632
D391 PR	Hêtre clair	121776
D381 PR	Hêtre	-
D382 PR	Hêtre rouge	074452
D375 PR	Érable	-
D2693 NA	Chêne velvet	-
D2240 VL	Chêne niagara	-
D741 PR	Chêne foncé	-
D2216 VL	Chêne chamonix	121782
D339 PR	Frêne blanc	-
D1432 BS	Bouleau luna	-
D2541 NA	Swiss elm froid	121757
D1350 BS	Pommier clair	121755
D991 BS	Pommier trentino	121775
D1251 VL	Poirier clair andora	121764
D1353 BS	Poirier clair	121786
D727 BS	Poirier	-
D227 BS	Poirier naturel	-
D355 PR	Pin de fil	074418
D2531 VL	Pin toscane	121784
D344 PR	Cerisier	121779
D1361 BS	Cerisier nevada	121779
D2342 VL	Teak miel	121769
D1378 BS	Wengé ebony	-
D722 PR	Noyer	070790
D2284 BS	Zebrano	121797
D620 PR	Aulne naturel	121778
D1243 BS	Nocerry	121781
D2441 BS	Makassar	070792
K101 Brillant	Blanc faces	070789
U190 Brillant	Noir	070788

Chants mélaminés

Melamine edgings
Melamin
Kantenumleimer
Cantos Melamínicos

Pré encollé

pre-glued • mit
Schmelzklebe
con cola

L. 23 mm

L. 25 ml

Placage bois

Wood veneer • Echtholz Furniere
Chapa madera

L.2,50 ml Ep.0,6 mm

u.c. **x 1**



Illustrations d'utilisation

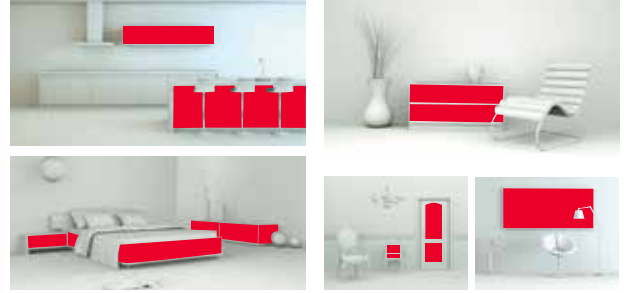

	Non Encollé (Plac-nor) non pre-glued ohne Schmelzkleber sin cola		Pré Encollé (Plac-fix) pre-glued mit Schmelzklebe con cola	
l.	25 cm	50 cm	25 cm	50 cm

Décor	Ref Pdt			
Acajou Mahogany • Mahogoni • Caoba	500100 8	500300 2	510000 8	510200 2
Chêne Oak • Eiche • Roble	500101 5	500301 9	510001 5	510201 9
Hêtre Beech • Buche • Haya	500111 4	500210 4	510018 3	510017 6
Koto	500103 9	500303 3	510003 9	510203 3
Merisier Cherry • Kirsche • Cerezo	500104 6	500304 0	510004 6	510204 0
Noyer Walnut • Nußbaum • Nogal	500105 3	500305 7	510005 3	510205 7
Pin Pine • Kiefer • Pino	500107 7	500307 1	510007 7	510207 1
Teck Teak • Teakholz • Teca	500109 1	500309 5	510009 1	510209 5

Revêtement adhésif

Self-adhesive foil
Selbstklebefolie
Pelcula autoadesiva



Auto Adhésif (Placflex)

Self-adhesive • Selbstklebend
Autoadhesivo

l.	0,90 ml
L.	2,15 ml
u.c.	x 1

Décor	Ref Pdt
Aluminium brossé Alu	600013 0
Blanc White • weiss • blanco	600001 7
Chêne Oak • Eiche • Roble	600002 4
Hêtre Beech • Buche • Haya	600011 6
Merisier Cherry • Kirsche • Cerezo *	600004 8
Poirier Pear • Birnbaum • Peral *	600003 1
Wengé Wenge *	600000 0
Inox	600015 4
Cuivre brossé	600016 1
Graphite brossé *	600017 8
Relief damier alu *	600014 7
Relief square alu *	600019 2
Relief square mix alu *	600020 8
Relief smart cuivre *	600021 5

* Jusqu'à épaisseur du stock

* Disponible courant 2016





PANNEAU
Placage



NOUVEAU

Plaque composite Alu

Aluminum Composite Panel
Aluminium-Verbundplatte
Panel de aluminio y composite



ALU



BLANC

L. 120 cm H. 80 cm Ep. 3 mm

u.c. x 1



Décor

Blanc White • weiss • blanco

Aluminium brossé Alu

Ref Pdt

780029 6

780028 9



- ✓ Léger
- ✓ Facile à découper
- ✓ Facile à fixer

Light • Leicht • Ligero

Easy to cut • Einfach zu schneiden • Fácil de cortar

Easy to install • Einfach zu befestigen • Fácil de instalar

AVANT Before • Vorher • Antes



APRÈS After • Nachher • Después

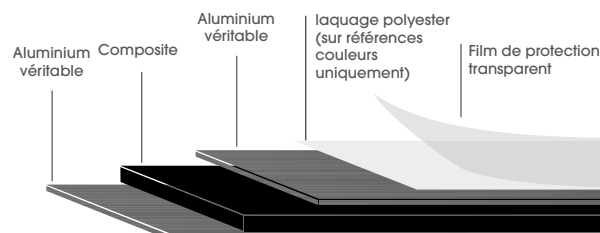



Profils plastiques

Plastic Profile • Plástica Profile • Perfiles plásticos

Angle

Désignation	Couleur	ℓ.	L.	Ref Pdt
Profilé de renvoi d'angle (YR) Reversing angle profile Doppel-Eck-Profil Perfil doble ángulo	Blanc White Weiss Blanco	16 mm	2,75 ml	670051 1
		19 mm		670050 4
Profilé de construction d'angle (PCA) Profile for angle construction Bauprofil für winkel Perfil construcción de angulo	Blanc White Weiss Blanco	18-19 mm		670184 6
Profilé Quart de rond (PQR) Quarter round profile Viertel kreis profil Perfil cuarto de luna	Blanc White Weiss Blanco	15 x 15 mm	3 ml	670075 7
Cornière de finition (LR) Finishing profile Fertigstellung Eck-profil Perfil de terminación	Blanc White Weiss Blanco	15 mm	2,75 ml	670084 9
		20 mm		670052 8
		25 mm		670091 7
		30 mm		670085 6
		35 mm		670086 3
		40 mm		670087 0
50 mm	670088 7			

Jonction de panneaux

Désignation	Couleur	ℓ.	L.	Ref Pdt
Profilé en H de raccord (HR) H profile H Profil Perfil plastico en H	Blanc White Weiss Blanco	3-4 mm	2,75 ml	670096 2
		10 mm		670115 0
		16 mm		670049 8
		19 mm		670048 1
Profilé en T de raccord (TR) T Profile T Profil Perfil en T	Blanc White Weiss Blanco	25-18 mm	2,75 ml	670169 3



Chant du Panneau

Chant rigide type U (UR) U Type rigid edgings
 U Förmige Hart Kanten • Perfiles U rígido

u.c. x 25

ℓ.	8 mm	10 mm	12 mm	16 mm	19 mm	22 mm
	L.	2,75 ml				
Décor	Ref Pdt					
Blanc White • Weiss • Blanco	670093 1	670037 5	670038 2	670039 9	670036 8	670040 5
Noir Black • Schwarz • Negro	-	-	-	-	670064 1	-
Gris Grey • Grau • Grisalla	-	-	-	-	670065 8	-
Chêne clair Oak • Eiche • Roble	-	-	-	-	670062 7	-
Hêtre Beech • Buche • Haya	-	-	-	-	670070 2	-

Profilé «Queue de sapein»

Thermo-plastic edge "T" profile • Thermo-plastisches "T" profil • Perfiles termo-plásticos tipo "Espina de pescado"



u.c. x 1

Arasable (QSA) Anchnittsfähig • Retilable

ℓ.	15-21 mm	21-26 mm
	L.	25 ml
Décor	Ref Pdt	
Blanc White • Weiss • Blanco	720019 5	-
Noir Black • Schwarz • Negro	720020 1	019017 2
Gris/Noir Grey/Black • Grau/Schwarz Grisalla/Negro	720022 5	019011 0

Couvre chant souple (CCS) Soft plastic covering edgings
 Umschließende Weichkunststoff-kanten • Cubrecantos flexible

u.c. x 1

ℓ.	16 mm	19 mm	16 mm	19 mm
	L.	2 ml		25 ml
Décor	Ref Pdt			
Blanc White • Weiss • Blanco	670000 9	670009 2	670054 2	670041 2
Noir Black • Schwarz • Negro	670001 6	670010 8	670053 5	670118 1
Aluminium Alu	670128 0	670129 7	670147 1	670146 4
Chêne clair Oak • Eiche • Roble	670006 1	670015 3	670061 0	670148 8
Hêtre clair Beech • Buche • Haya	670007 8	670016 0	670059 7	670108 2
Merisier Cherry • Kirsche • Cerezo *	670008 5	670017 7	670060 3	670068 9

Demi-rond creux (QSDC) Empty half round • Halbrund hohl
 Media luna hueco

u.c. x 1

ℓ.	20 mm	25 mm	30 mm
	L.	25 ml	
Décor	Ref Pdt		
Blanc White • Weiss • Blanco	019004 2	-	-
Bleu Blue • Blau • Azul	019022 6	-	-
Gris Grey • Grau • Grisalla	019002 8	019007 3	019010 3
Noir Black • Schwarz • Negro	019001 1	019008 0	019009 7
Rouge Red • Rot • Rojo	019005 9	-	-

Demi-rond plein (QSP) Full half round • Halbrund flach, massiv
 Media luna macizo

u.c. x 1

L.	100 ml	ℓ.	19 mm
Décor	Ref Pdt		
Blanc White • Weiss • Blanco	019013 4		
Noir Black • Schwarz • Negro	019012 7		

* Jusqu'à épuisement du stock



CUISINE

Crédence
Plan de travail



Profil alu Profiles • Profile • Perfiles

L. ± 670 mm

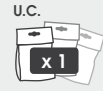

- Bien identifier la forme du plan, son épaisseur et son rayon de section.
- L'outil malin pour vous aider à choisir le profil correspondant à votre plan de travail. Pour cela, utilisez les gabarits à l'échelle ci-dessous.

Information for identification of the board, thickness and radius

Informationen zur Klassifizierung der Platte, Stärke und Radius

Identificar la forma de la encimera, su espesor y su radio

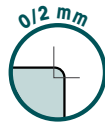
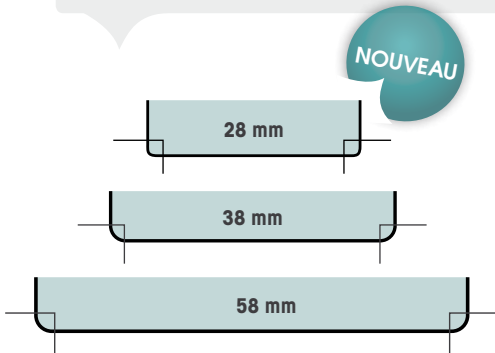
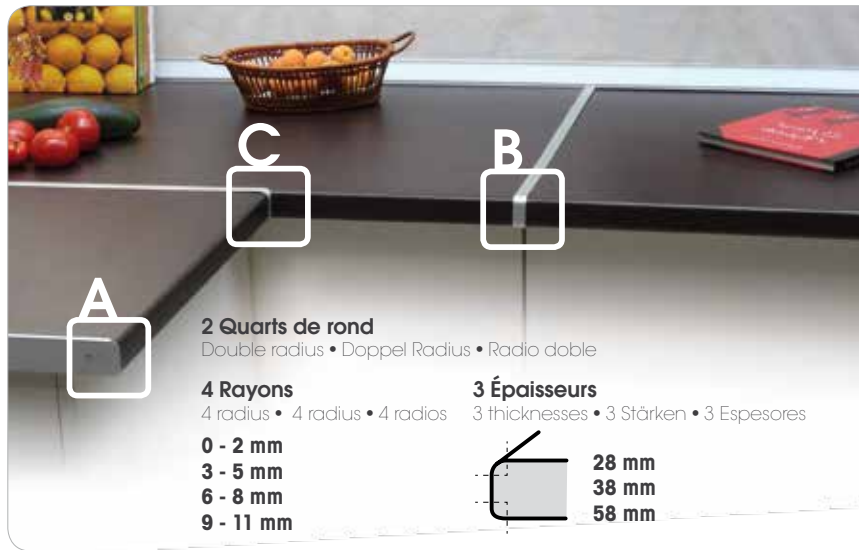

	A			B			C		
	Finition bordure End cap profile Endkappenprofil Terminación Reborde			Jonction bord à bord Straight run joint profile Gerades Verbindungsprofil Unión			Jonction d'angle Corner joint profile Verbindungsprofil Unión de ángulo		
Ep.	28 mm	38 mm	58 mm	28 mm	38 mm	58 mm	28 mm	38 mm	58 mm
Décor	Ref Pdt								
Aluminium Alu	680176 8	680151 5	680154 6	680177 5	680152 2	680155 3	680178 2	680153 9	680156 0

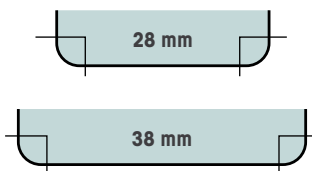
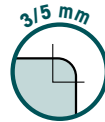

	A		B		C	
Ep.	28 mm	38 mm	28 mm	38 mm	28 mm	38 mm
Décor	Ref Pdt					
Aluminium Alu	680106 5	680100 3	680124 9	680118 8	680115 7	680109 6
Blanc White • Weiss • Bianco	680107 2	680101 0	680125 6	680119 5	680116 4	680110 2
Noir Black • Schwarz • Negro	680108 9	680102 7	680126 3	680120 1	680117 1	680111 9

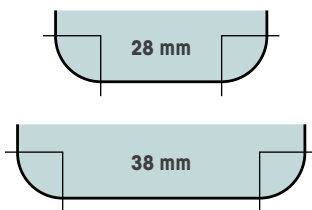

	A		B		C	
Ep.	28 mm	38 mm	28 mm	38 mm	28 mm	38 mm
Décor	Ref Pdt					
Aluminium Alu	680145 4	680014 3	680147 8	680016 7	680146 1	680015 0
Blanc White • Weiss • Bianco	680148 5	680017 4	680149 2	680020 4	680150 8	680023 5

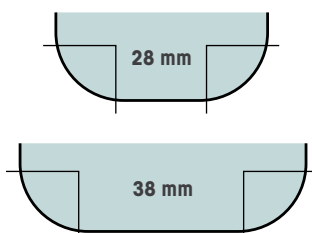

	A		B		C	
Ep.	28 mm	38 mm	28 mm	38 mm	28 mm	38 mm
Décor	Ref Pdt					
Aluminium Alu	680002 0	680112 6	680008 2	680113 3	680011 2	680114 0
Blanc White • Weiss • Bianco	680004 4 *	680142 3	-	680143 0	-	680144 7

* Jusqu'à épaisseur du stock



CUISINE

Crédence
Plan de travail



Profil pour îlot de cuisine

Kitchen island junction trim
Küchenverbindungsprofil
Perfil de union para cocinas

ALU | L. 2 m Ep. 38 mm



Ref Pdt 680044 0

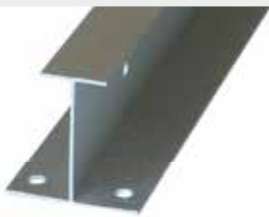

NOUVEAU

Plaque composite Alu*

Aluminum Composite Panel • Aluminium-Verbundplatte • Panel de aluminio y composite



ALU BROSSÉ



BLANC

L. 120 cm

H. 61 cm

Ep. 3 mm

u.c. x1



Décor	Ref Pdt
Blanc • White • weiss • blanco	780031 9
Aluminium brossé • Alu	780030 2



- ✓ Léger
- ✓ Facile à découper
- ✓ Facile à fixer

Light • Leicht • Ligero
 Easy to cut • Einfach zu schneiden • Fácil de cortar
 Easy to install • Einfach zu befestigen • Fácil de instalar

* Disponible courant 2016



CUISINE

Crédence
Plan de travail



Support de snack Breakfast bar • Snack Bodenträger • Soporte de estante snack

• Pour créer un espace bar/snack convivial ; une console desserte dans une cuisine ouverte, ou simplement pour disposer de plus d'espace de travail To create a friendly bar / snack area , a service shelf in an open kitchen or simply to have more workspace • Um eine freundliche Bar / Snack-Bereich, ein Service Regal in einer offenen Küche zu schaffen oder einfach, um mehr Arbeitsfläche haben • Para crear un espacio barra / snack agradable , un estante de servicio en una cocina abierta, o simplemente para tener más espacio de trabajo.

Support de snack Zen



ALU ANODISÉ



- Pied mono bloc
- Matériau : aluminium anodisé
- Vis inox fournies

Monoblock stand
Integralträger
Soporte monobloque.
Anodized aluminum
Eloxiertem Aluminium
Aluminio anodizado.

Stainless steel screws
provided • Mit Edelstahl-
Schrauben • Con
Tornillos de acero
inoxidable.

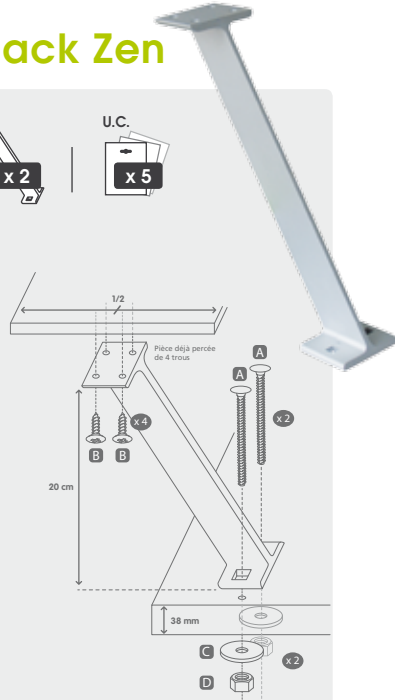

Ref Pdt 780011 1

NOUVEAU

Support de snack Urban alu basic design *



ALU



- Hauteur posé : 20 cm • Monobloc / Pré-percé
- Quincaillerie fournie • Aluminium véritable
- Rapport qualité/prix

Installed height • Montagehöhe • Altura de
instalación. One-piece bracket / With screw holes
• Integralträger / Vorgebohrt • Soporte monobloque
/ Preperforado. Hardware provided • Kleinteile inkl •
Herrajes incluidos. Genuine aluminium • Aluminium •
Aluminio auténtico. Excellent value • Sehr gutes Preis /
Leistungsverhältnis • Excelente relación calidad-precio

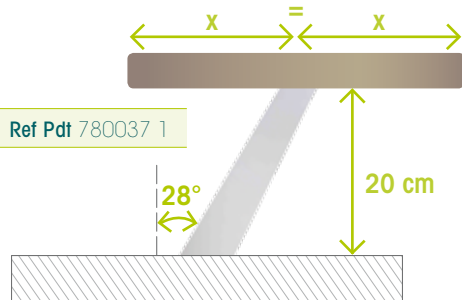

Ref Pdt 780037 1

NOUVEAU

Support de snack droit Calao* (20 cm - finition chromé)



ACIER CHROMÉ



- Hauteur posé : 20 cm • Quincaillerie fournie
- Notice de posé fournie • Robuste • Plaque
de support de tablette de 18 cm de longueur
pour une plus grande stabilité mais invisible
après pose.

Installed height • Montagehöhe • Altura de
instalación. Hardware provided • Kleinteile
inkl • Herrajes incluidos. Fitting instructions included • Mit
Montageanleitung • Instrucciones de montaje incluidas.
Robust • Robust • Robusto. Discreet and stylish • Formschön
und diskret • Discreto y de diseño



Ref Pdt 780034 0

* Disponible courant 2016

Support de snack incliné Sligo* (23 cm - finition chromé)



ACIER CHROMÉ



- Hauteur posé : 23 cm • Quincaillerie •
- Notice de pose fournie • Pour plan de
travail 2,8 cm ou 3,8 cm • Esthétique

Installed height • Montagehöhe • Altura
de instalación. Hardware provided
• Kleinteile inkl • Herrajes incluidos. Fitting instructions
included • Mit Montageanleitung • Instrucciones de
montaje incluidas. Attractive • Ästhetisch • Estético

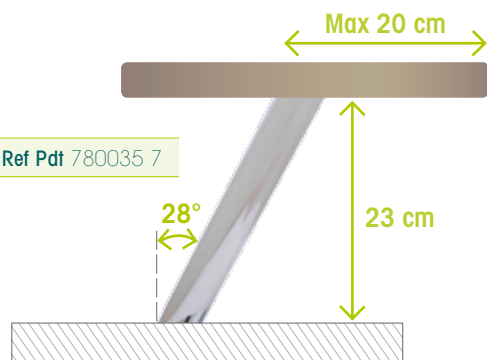

Ref Pdt 780035 7



CUISINE

Crédence
Plan de travail



NOUVEAU

Support de snack incliné Milano pour position contre mur* (finition chromé)



ACIER CHROMÉ



x 2



U.C.

x 3

- Pour fixation murale
- Hauteur posé : 23 cm
- Notice de pose fournies
- Esthétique

Installed height • Montagehöhe •
Altura de instalación

Fitting instructions included • Mit
Montageanleitung • Instrucciones de
montaje incluidas

Attractive • Ästhetisch • Estético



NOUVEAU

Support de snack incliné* (21 cm LUX - finition inox brossé)



ACIER



x 2



U.C.

x 3

- Hauteur posé : 21 cm
- Quincaillerie
- Notice de pose fournies
- Discret et Design

Installed height • Montagehöhe •
Altura de instalación

Hardware provided • Kleinteile inkl. • Herrajes incluidos

Fitting instructions included • Mit Montageanleitung •
Instrucciones de montaje incluidas

Discreet and stylish • Formschön und diskret • Discreto
y de diseño

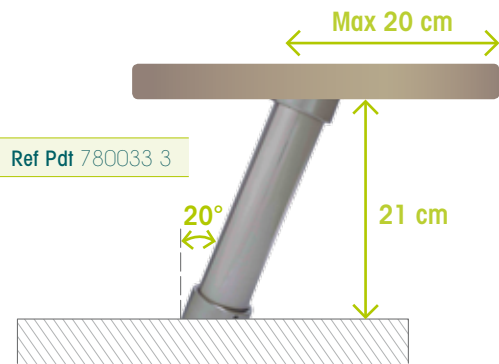
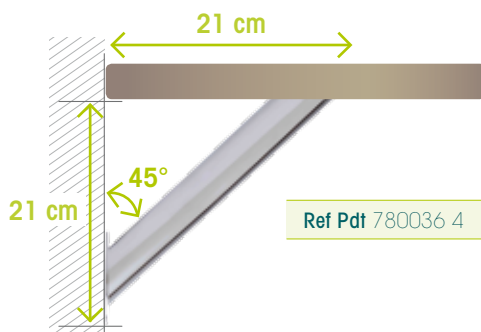

Fond de hotte

Stainless steel backsplash tiles • Edelstahl-
Spritzschutzplatten • Placas murales de cocina



INOX



x 1

U.C.

x 5



Silicon

L.60 cm H.70 cm

Ref Pdt 780016 6

L.90 cm H.70 cm

Ref Pdt 780017 3

Crédence basse

Stainless steel backsplash tiles • Edelstahl-
Spritzschutzplatten • Placas murales de cocina



INOX | L.120 cm H.15 cm



x 1

U.C.

x 4



Silicon

Ref Pdt 780018 0



- ✓ Facile à installer
- ✓ Préserve la propreté des murs
- ✓ Se pose derrière tout type de plaque de cuisson

Easy to install • Einfach zu installieren
• Instalación fácil.

Maintains walls clean • Behält
die Sauberkeit der Wände •
Mantiene las paredes limpias.

Behind any type of hob • Hinter
jedem Kochfeld • Detrás de
cualquier tipo de encimera

- ✓ Esthétique : accord parfait avec le fond de hotte inox
- ✓ Solution économique

Good value for money • Effiziente Lösung •
Solución económica



* Disponible courant 2016



CUISINE

Crédence
Plan de travail



Top protect Baguettes repose plat

Trivet blades • Topfuntersetzer Klingen
Tiras salvamantel



INOX

L. 25 cm H. 1 cm Ep. 2,5 mm



U.C.

x 5

Fixation : auto adhésif

Self adhesive • Verglasung • Autoadhesivo

Ref Pdt 780023 4



- ✓ Prêt à poser
- ✓ Pour tout type de plan de travail
- ✓ Gabarit de pose inclus

Ready to install • Bereit zu installieren • Listo para instalar
 For any kind of working top • Für jede mögliche
 Küchenarbeitsplatte • Para todas las encimeras de cocina
 Installation template included • Installation Vorlage
 enthalten • Plantilla de instalación incluido



Profil de finition de crédence

backsplash finishing profile • Abschlussprofil für Küchenwand
Perfil de acabado pared de cocina



ALU ANODISÉ

L. 3,15 m



x 1



U.C.

x 8



Silicon

- Adapté aux crédences de 8 à 10 mm
- Matériau : aluminium anodisé

Fits backsplash tiles from 8 to 10 mm • Passend Fliesen von 8 bis 10 mm
 Se adapta a azulejos de 8 a 10 mm
 Anodized aluminum • Eloxiertem aluminium • Aluminio anodizado

Ref Pdt 670209 6



- ✓ Simple et rapide à poser
- ✓ Esthétique et durable

Quick and easy to install • Einfach und schnell zu installieren
 Sencillo e instalación rápida
 Beautiful and sustainable • Schön und nachhaltig • Estético y sostenible

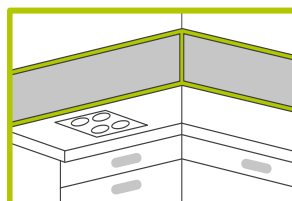
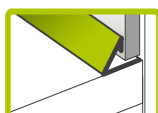
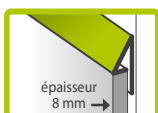



CUISINE

Crédence - Étanchéité
Plan de travail



Canules

Cannulas • Kanülen • Cànulas



Ref Pdt 780012 8



✓ Compatible avec toutes les cartouches (silicone, colle, mastic)

Compatible with all cartridges (silicone, glu, putty, ...)
Kompatibel mit allen Patronen (Silikon, Leim, Kitt, ...)
Compatible con todos los cartuchos (silicona, pegamento, masilla, ...)



Pare vapeur

Protective sheet • Pelicula de proteccion
Schutzfolie

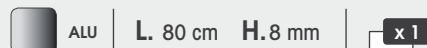

• Adhésif • Pose facile • Discret

Self adhesive • Easy to install • Discreet
Selbstklebend • Einfache Installation • Diskret
Auto adhesivo • Instalacion Facil • Discreto

U.C.

x 10

Ref Pdt 780019 7

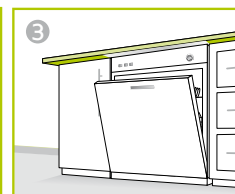
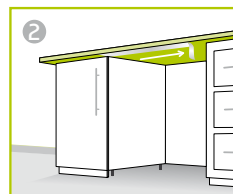
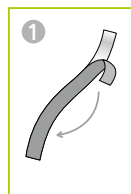

Profil de protection de plan de travail

Profile for the protection of kitchen working tops
Schutzprofil für Küchenarbeitsplatten
Perfil para la protección de encimeras de cocina



L. 3,15 ml H. 38 mm Ep. 11 mm

Ref Pdt 780024 1

NOUVEAU

L. 3,15 ml H. 28 mm Ep. 11 mm

Ref Pdt 780032 6

- Pour plan de travail de 38 mm d'épaisseur
- Pour plan de travail de rayon 0 à 9 mm

For 38mm working top • Für 38 mm Arbeitsplatte
Por encimeras de 38 mm
For working top with 0-9mm radius • Für Arbeitsplatte mit 0-9mm Radius • Por encimeras con radio de 0 à 9 mm



✓ Idéal neuf et rénovation

Perfect for new kitchen or renovation
Perfekt für neue Küche oder Renovierung
Perfecto para cocina nueva o renovación





CUISINE
Étanchéité



Profil de cuisine

Backsplash Profile "PREA-D"
Küchenprofil "PREA-D"
Perfil de cocina "PREA-D"

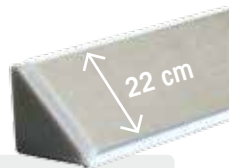

ALU
ANODISÉ

L. 3,15 m Ep. 22 mm



x 1



x 5

Matériau : plastique + aluminium

Ref Pdt 670211 9



- ✓ Pour une parfaite finition de la cuisine (entre crédence et plan de travail)
- ✓ Très résistant à la corrosion / abrasion / rayures
- ✓ Esthétique et discret
- ✓ Idéal pour la rénovation

For a perfect finish of the kitchen • Für ein perfektes Finish der Küche • Para un buen acabado

Highly resistant to corrosion / abrasion / scratches • Hohe Beständigkeit gegen Korrosion / Abrieb / Kratzer • Muy resistente a la corrosión / abrasión / rayas

Neat and discreet • Schick und diskret • Estético y limpio

Ideal for renovation • Ideal für die Renovierung • Ideal para la renovación



Kit de finition pour profil PREA-D

Accessory set for "PREA-D" backsplash profile
Zubehöre für Küchenprofil "PREA-D"
Accesorios para perfil de cocina "PREA-D"

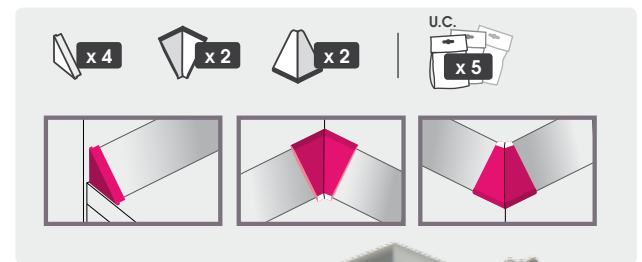

Ref Pdt 670212 6

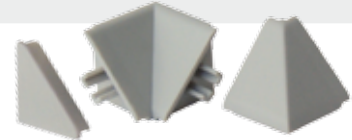

Profil de cuisine CARRÉ*

NOUVEAU

Backsplash Profile "PREAD CARRÉ"
Küchenprofil "PREAD CARRÉ"
Perfil de cocina "PREAD CARRÉ"



ALU
ANODISÉ

L. 3,15 m Ep. 11 mm H. 25 mm

Matériau : Aluminium et PVC



x 5 u.c.

Ref Pdt 670224 9

Ref kit 670225 6

Composition
du kit



x 2

ANGLE
SORTANT



x 2

ANGLE
RENTRANT



x 4

ANGLE
FINITION

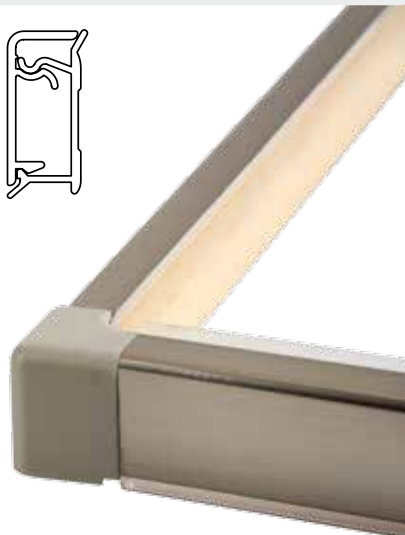
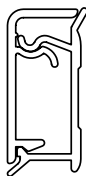

Profils XS C et XS B

Profile • Profil • Perfil



ALU • BLANC
NOIR

L. 3,15 m



x 1



x 1



x 5



x 5



Silicon



OU
Vis



- ✓ Livré avec 4 embouts droit de finition + 2 embouts rentrants + 2 embouts sortants

Delivered with 4 flat stamps + "2 out" pieces + "2 in" pieces • Mit 4 Abschlusskappen inklusive + 2 Aussenecke + 2 Innenecke • Entregado con 4 topos laterales + 2 topos de angulo saliente + 2 topos de angulo entrante

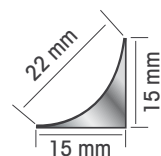

XS C

Ref Pdt

Aluminium 670205 8

Blanc 670214 0

Noir 670213 3

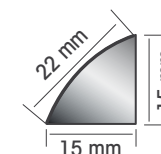

XS B

Ref Pdt

Aluminium 670206 5



* Disponible courant 2016



Joint plastique

Sealing tape • Wasserdichtung
Junta de estanqueidad



ALU



BLANC

L. 3 m



x 1

U.C.



x 5

Pour la réalisation de joint d'étanchéité entre le plan de travail et le mur.

To make a seal between the working top and wall
• Eine Dichtung zwischen der Arbeitsplatte und Wand erzielen • Para lograr un sellado hermético entre la encimera y la pared

Ref Pdt

Blanc	780001 2
Gris Alu	780007 4



- ✓ Recoupe facile
- ✓ Discret
- ✓ Remplace avantageusement le silicone
- ✓ Épouse la forme du support

Easy to cut • Leicht zu schneiden • Corte fácil
Discret • Diskret • Discreto
Replaces silicone • Ersetzt Silikon • Reemplaza ventajosamente la silicona
Conforms to the contours of the support • Passt sich der Form des Trägers • Se acopla a la forma de la base

Mastiplast

Sealing tape • Wasserdichtung • Junta de estanqueidad



BLANC

l. 9 mm L. 3 m



x 1

U.C.



x 1

Ref Pdt 780002 9

- Cuisine, salle de bain, vitrage
- Fixation : auto adhésif

Sealing tape : self adhesive, multi-use
Dichtung für : Verglasung, Küchen, Badezimmer
Junta de estanqueidad : autoadhesivo, multiuso

- ✓ Facile à poser
- ✓ Étanche
- ✓ Propre

Easy to set, water-tight and clean
Einfach, Wasserdicht, Sauber
Instalación sencilla, estanque, limpio

NORDLINGER pro JOINT D'ÉTANCHÉITÉ **Mastiplast** 3m



BLANC • auto-adhésif



Cuisine - Vitrage - Salle de Bain 





CUISINE

Accessoires pour Plinthes



Raccord de plinthes agglo

Fittings for skirting boards
Anschlüsse für Sockelleisten
Unión para rodapiés agglo

H.150 mm
Ep.16/19 mm

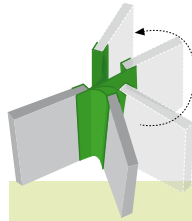

Angle Universel

Universal corner
Universal-Winkel
Angulo universal



Angle Droit

Angle Junction
Winkelanschlussstück
Angulo recto

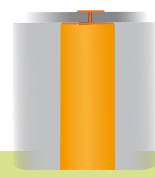

Jonction Droite(H)

Straight Junction
Gerade Verbindung
Union Recta



Profil de Finition(U)

End cap profile
Endkappen Profil
Perfil de acabado



Kit raccords de Plinthe

Fittings for skirting boards • Anschlüsse für Sockelleisten • Kit uniones de rodapiés

UNIT	x 4	x 4	x 4	x 4	2U+2H+2 angles droits
Décor	Ref Pdt				
Gris alu Alu	790024 8	790027 9	790030 9	790033 0	790036 1
Blanc White • Weiss • Blanco	790025 5	790028 6	790031 6	790034 7	790037 8
Noir Black • Schwarz • Negro	790026 2	790029 3	790032 3	790035 4	790038 5

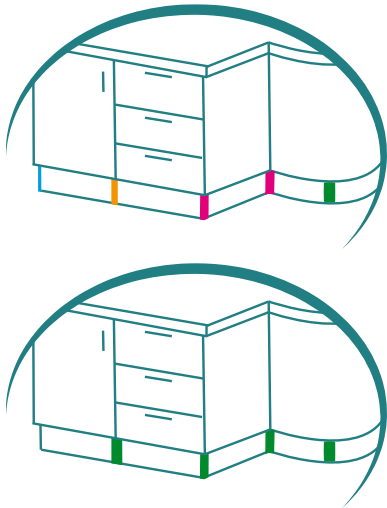

U transparent

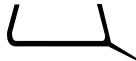

U transparent • U transparent
U transparente

u.c.



L.2,60 m Ep.16/19 mm

Ref Pdt 670074 0





CUISINE

Accessoires meubles



Support micro-onde

Microwave wall bracket
Wandhalterung für Mikrowelle
Soporte de pared para microondas

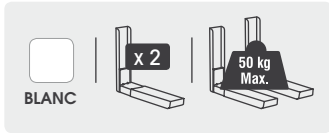

Ref Pdt 780021 0



Cache vis

Screw hider • Selbstklebende
Abdeckkappen • Tapas autoadhesivas

BLANC • HÊTRE
GRIS • NOIR

x 100

U.C. x 10

Ø 13 mm

Fixation : auto adhésif
Self adhesive
Selbstklebende
Autoadhesivas

	Ref Pdt
Blanc	650600 7
Hêtre	650602 1
Gris	650605 2
Noir	650604 5



Freins de porte

Kitchen door brake • Küchentür
Bremse • Amortiguador de
puerta de cocina



x 4 x 8

U.C. x 1

Ref Pdt 780009 8

Cuisine, meuble

Kitchen, furnitue
Küchen, nöbel
Cocina, Mueble

x 100

Ref Pdt 780010 4



✓ Fini les portes qui claquent !

No more slamming doors ! • Nie mehr Zuschlagen von Türen !
No mas puertas golpeando !

Cales pour la pose du parquet

Wedges for parquet laying • Abstandskelle für die Verlegung von Parkett • Cuñas para la colocación de parquet

Cale «lift top»

BLEU

x 6

U.C. x 5

Cale de montage plastique
Plastic lifting wedge • Kunststoffhebekeil
Cuña de elevación de plástico



Cale «lift XL»

JAUNE

x 1

U.C. x 5

Pour la pose d'un parquet, pour soulever facilement les vitres, pour dégondrer les portes ou soulever plaques de plâtres et d'isolant.

To lay parquet flooring , to easily lift glass , to unhinge doors or lift insulation and plasterboards • Um Parkettböden zu verlegen , um leicht Glas zu heben , Türen aus den Angeln zu heben oder um Isolierung und Gipsplatten zu heben
• Para la colocación de parquet, para levantar fácilmente los vidrios, para desquiciar puertas o levantar placas de yeso y aislamiento.



Ref Pdt 740051 9



✓ Utilisable des 2 côtés

May be used on both sides • Wird auf beide Seiten verwendet • Se usa los 2 lados



SOL & MUR
Sol



Plinthe cache fil PVC et embouts de finition

Plastic skirting board and assembling and finition kit • Kunststoff-Sockelleiste und montage und fertigungszubehöre • Rodapie cubrecable PVC y topes de acabado



BLANC • CHÊNE NATUREL • CHÊNE BLANC • CHENE GRIS
CHENE DORÉ • GRIS • GRIS ALU • ARDOISE FONCÉ

Plinthe cache fil PVC

Plastic skirting board • Kunststoff-Sockelleiste • Rodapie cubrecable PVC

L. 2,5 m H. 6 cm Ep. 1,2 cm

u.c.

x 10

À coller ou visser

Glue or screw mounted
Montage mit Leim oder Schrauben
Se instala con cola o con tornillos

	Ref Pdt
Blanc	790000 2
Chêne naturel	790001 9
Chêne blanc	790002 6
Chêne gris	790042 2
Chêne doré	790044 6
Gris *	790003 3
Gris alu	790041 5
Ardoise foncé	790045 3



Kit de finition

Assembling and finition kit
Montage-und fertigungszubehöre
Kit de acabado

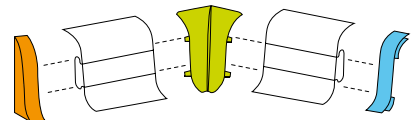
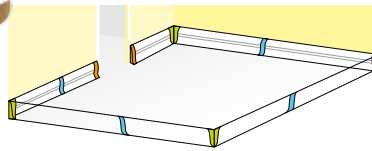

u.c.



Kit : 2 embouts droits + 4 angles
rentrants + 4 jonctions droites

Kit : 2 endcaps + 4 outward angles + 4 straight junctions
Kit : 2 Endkappen + 4 Außen Winkeln + 4 gerade Kreuzungen
Kit : 2 tapas + 4 angulos abiertos + 4 uniones rectas

	Ref Pdt
Blanc	790004 0
Chêne naturel	790005 7
Chêne blanc	790006 4
Chêne gris	790047 7
Chêne doré	790049 1
Gris *	790007 1
Gris alu	790046 0
Ardoise foncé	790050 7

Kit angles

Angle kit • Kit für Winkel
Kit angulos

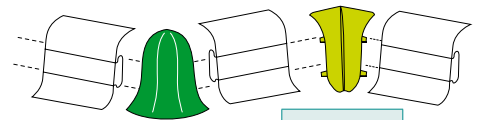
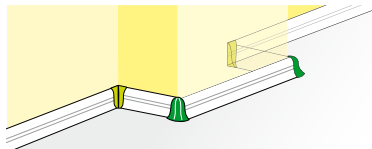

u.c.



Kit : 1 angle rentrant + 1 angle sortant

Kit : 1 outward angle + 1 inward angle
Kit : 1 außen winkeln + 1 innen winkeln
Kit : 1 angulo abierto + 1 angulo cerrado

	Ref Pdt
Blanc	790012 5
Chêne naturel	790013 2
Chêne blanc	790014 9
Chêne gris	790052 1
Chêne doré	790054 5
Gris *	790015 6
Gris alu	790051 4
Ardoise foncé	790055 2

Kit prise & jonctions

Socket and connection kit
Kit Steckdose und Anschluss
Kit enchufe electrico y empalmes rectos

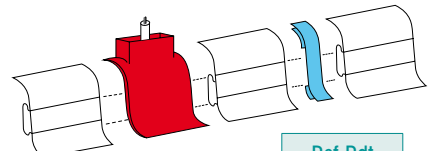
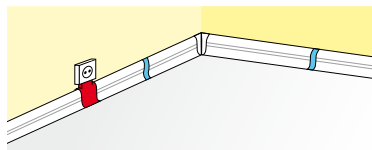

u.c.



Kit : 1 sortie de prise + 2 jonctions droites

Kit : 1 plug outlet + 2 straight junctions
Kit : 1 steckersverbindung + 2 gerade kreuzungen
Kit : 1 salida enchufe + 2 uniones rectas

	Ref Pdt
Blanc	790020 0
Chêne naturel	790021 7
Chêne blanc	790022 4
Chêne gris *	790057 6
Chêne doré *	790059 0
Gris *	790023 1
Gris alu *	790056 9
Ardoise foncé *	790060 6

* Jusqu'à épuisement du stock

* Disponible courant 2016



SOL & MUR
Mur



BIEN
VU



Voir
p. 42

NOUVEAU
DESIGN



Clips à lambris

Panelling hooks • Täferkrallen • Grapas para frisos

Clips pour lambris en pose murale

CLIPS + POINTES

- HOOKS + NAILS • HAKEN + NÄGELN
- GRAPAS + CLAVOS

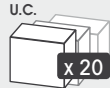

Clips pour lambris en pose plafond

CLIPS + VIS

- HOOKS + SCREW • HAKEN + SCHAUBE
- GRAPAS + TORNILLOS

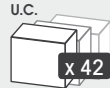

Lambris bois • Panelling wood
Holz Täfer - Holz • Friso Madera

	Pour lambris d'épaisseur de	±	m ²	Ref Pdt
3 mm	10-12 mm	100	5	740100 4
		250	10	740101 1
4 mm	13-16 mm	250	10	740106 6
5 mm	18-21 mm	200	10	740105 9

Lambris PVC • Panelling PVC
• Holz Täfer PVC • Friso PVC

	Pour lambris d'épaisseur de	±	m ²	Ref Pdt
1 mm	6-12 mm	250	10	740103 5

Lambris MDF • Panelling MDF
• Holz Täfer MDF • Friso MDF

	Pour lambris d'épaisseur de	±	m ²	Ref Pdt
1,6 mm	6-12 mm	250	10	740104 2

	Pour lambris d'épaisseur de	±	Ref Pdt
3 mm	10-12 mm	100	740107 3



✓ Invisible après pose

Invisible after installation • Unsichtbar nach der Installation
Invisible después de la instalación

Cloueur manuel

Hand nailer • Handnagler • Aparato de clavado manual



Ref Pdt 740109 7

- ✓ Embout magnétique retenant le clou
- ✓ Plus de confort de pose
- ✓ Permet d'enfoncer le clou sans se faire mal aux doigts

Magnetic end to hold the nail Magnetische • Spitze, um den Nagel zu halten • Punta magnética para sujetar el clavo.
Easier to instal • Einfacher zu installieren • Más fácil de instalar.
Allows nailing without hurting fingers • Ermöglicht Nageln ohne zu verletzen Finger • Permite clavar sin lastimarse los dedos.



Pince à lambris

Panelling pliers • Paneelzange • Tenazas panel



Pour le maintien de la lame durant le clipsage en pose plafond, permettant ainsi de poser seul le lambris.

Grâce à sa molette de réglage, plusieurs lames sont maintenues en suspension afin d'éviter de se déplacer à la pose de chaque nouvelle lame.

Holds the panel while being clipped on the ceiling, allowing one person to do the work alone • Hält die Platte, während sie an der Decke befestigt wird, so dass eine Person die Arbeit allein machen kann • Mantiene el panel mientras esta fijado al techo, lo que permite a una persona sola de hacer el trabajo.



Ref Pdt 740108 0

- ✓ Permet de poser seul du lambris au plafond
- ✓ Permet de gagner du temps

Allows one person alone to put in ceiling panels • Ermöglicht eine Person, allein Deckenplatten zu setzen • Permite que una sola persona pueda poner paneles de techo.
Time saving • Zeitersparnis • Ahorra tiempo



Taquets d'assemblage

Wedges for panel assembling • Verbindungskeil für Sperrholzplatten • Tacos de ensamblaje para paneles

Assemblage de tablettes, panneaux, étagères

Assembling of shelves and panels
Befestigung von Fachböden, Paneelen und Regalen
Fijación de estantes y paneles

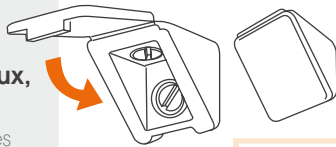

8 Taquets 8 wedges 8 keile 8 tacos	16 Taquets 16 wedges 16 keile 16 tacos	32 Taquets 32 wedges 32 keile 32 tacos	4 Taquets double hauteur 4 double width wedges 4 doppelbreite keile 4 tacos doble anchura	8 Taquets 8 wedges 8 keile 8 tacos
--	--	--	---	--



U.C.

x 10

x 16

x 10

x 10

x 400

Décor	Ref Pdt				
Blanc White • weiss • blanco	740025 0	740028 1	740046 5	740048 9	740026 7
Beige	740027 4	740029 8	740047 2	-	740030 4
Gris alu Grey alu • Grau alu • Gris alu	740056 4	-	740057 1	-	-

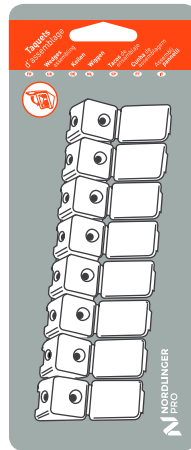

- ✓ Fixation invisible
- ✓ Permet d'assembler meuble, placard, dressing facilement et rapidement

Concealed fixing • Verdeckte Befestigung Fijación oculta

Used to assemble furniture and wardrobes quickly and easily • Um Möbel und Schränke schnell und einfach zusammenzubauen • Se utiliza para montar muebles y armarios rápidamente y fácilmente.

Tourillons

Dowels • Dübel • Clavijas



U.C.



Ø 8 mm x 40

Ref Pdt 780013 5

U.C.



Ø 10 mm x 30

Ref Pdt 780014 2

Assemblage de tablettes, panneaux, étagères

Assembling of shelves and panels
Befestigung von Fachböden, Paneelen und Regalen
Fijación de estantes y paneles





Jonc de rotin

Rattan • Rohrstück • Junco

u.c.



L. 1,70 m

Ref Pdt 890500 6



u.c.

x 1

L. 1,70 m

Ref Pdt 890600 3



Rouleau de cannage

Canework roll • Rohgeflecht rohr • Rollo de rejilla

u.c.



x 2

l. 0,45 m L. 0,5 m

Ref Pdt 890003 2

u.c.



x 1

l. 0,61 m L. 1 m

Ref Pdt 890000 1



- ✓ **Qualité siège**
- ✓ **Résistant au poids**

Seat quality • Weight resistant
Qualität Sitz • Unempfindlich gegen Gewicht
Calidad de silla • Resistente al peso

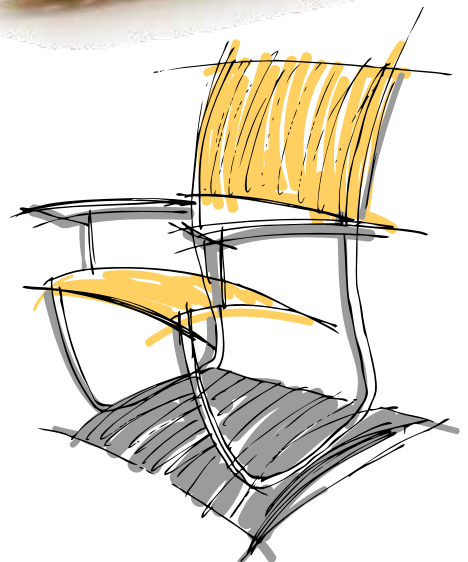



Bande anti-dérapante

Anti-slip tape • Antirutschband
Cinta antideslizante

U.C.



L. 6 ml l. 25 mm

- Bande auto-adhésive
- Pour marches d'escalier

Adhesive tape • Klebeband • Cinta adhesiva
For stairs • Für Treppen • Para escaleras

Ref Pdt 742025 8



✓ Sécurise l'escalier

Makes stairs safer • Macht Treppen sicherer
Hace las escaleras más seguras

Lattes de sommier

Springing lath • Bettlatten • Lamas de somier

U.C.



Ep. 8 mm



l.	38 mm	53 mm	63 mm
Largueur du lit / Bed width / Bettbreite • Ancho de cama	Ref Pdt		
70 cm		(A) 741000 6	-
90 cm	(C) 741004 4	(B) 741001 3	(E) 740003 8
140 cm		(D) 741006 8	-



Embouts de latte plastique

Plastic tips • Plastik Kappen • Topes de plastico



U.C.



Ep. 8 mm

①

②

③

④

⑤



l.	38 mm	53 mm	63 mm
	Ref Pdt		
À clouer / To nail • Zum Annageln • Para clavar	(1) -	741002 0	-
	(2) -	-	740004 5
À clipser / To brooch • Zum Anklemmen • Con clips	(3) -	741003 7	-
	(4) -	-	741013 6
Double à clipser / Doppel to brooch • Doble Zum Anklemmen • Con clips	(5) 741005 1	-	-



Tréteau Promalin métal

JAUNE | U.C. x 4 | x 2 | **350 kg Maxi** | 3,95 kg net
pour 2 tréteaux

- Matériau : Métal
- Revêtement antidérapant sur la traverse supérieure
- Poignée plastique épaisse et souple

Plastic handle, thick and flexible
Kunststoffgriff, dick und flexibel
Mango de plástico grueso y flexible

Ref Pdt 640025 1

↑ 78 cm ← 100 cm ↗ 50 cm

↓ 6,5 cm ← 100 cm ↗ 10 cm



- ✓ Facile à plier et à transporter
- ✓ Pieds pliables avec rangement intégré dans le cadre du tréteau
- ✓ Traverse supérieure large pour plus de confort à l'usage

Easy to fold and carry • Leicht zu falten und zu tragen • Fácil de plegar y llevar - Removable legs with integrated storage in the trestle frame • Abnehmbare Beine mit integriertem Stauraum im Bockrahmen • Patas desmontables con almacenamiento integrado en el marco del caballete - Wide top bar for comfort in use • Breite Leiste oben für Komfort im Einsatz • Base superior ancha para mayor comodidad en uso.

Tréteau PRO kit

NOIR | U.C. x 4 | x 1 | **300 kg Maxi** | 5,30 kg net
pour 2 tréteaux

- Matériau : métal
- Tréteau professionnel réglable en hauteur
- Charge lourde

Ref Pdt 640023 7

1 seul mouvement

↑ 79 cm à 120 cm ← 75 cm ↗ 57 cm

↓ 84 cm ← 75 cm ↗ 9 cm



- ✓ Robuste
- ✓ Réglable en hauteur
- ✓ Pliable pour être peu encombrant
- ✓ Rapport qualité/prix exceptionnel
- ✓ Ouverture et blocage simplifiés en un seul mouvement

Strong • Robust • Robusto - Adjustable height • Höhenverstellbar • Altura ajustable - Foldable therefore takes up little space • Faltpar nimmt daher wenig Platz • Plegable, por lo tanto ocupa poco espacio - Exceptional price / quality ratio • Außergewöhnliches Preis / Leistungsverhältnis • Relación calidad / precio excepcional - Simplified implementation in one movement • Vereinfachte Umsetzung in einer Bewegung • Aplicación simplificada con un solo movimiento.

Tréteau Essentiel H

NOIR | U.C. x 4 | x 2 | **300 kg Maxi** | 2,87 kg net
pour 2 tréteaux

- Matériau : métal
- Pieds démontables avec rangement intégré dans le cadre du tréteau

Removable legs with integrated storage in the trestle frame • Abnehmbare Beine mit integriertem Stauraum im Bockrahmen • Patas desmontables con almacenamiento integrado en el marco del caballete

↑ 75 cm ← 75 cm ↗ 50 cm

↓ 50 cm ← 75 cm ↗ 2,5 cm



- ✓ Transport et rangement facilités
- ✓ Gain de place
- ✓ Pieds démontables sans outil
- ✓ Installation et démontage rapides
- ✓ Stabilité
- ✓ Extrémités tubulaires bouchées

Easy transport and storage • Einfache Transport und Lagerung • Transporte y almacenamiento fáciles - Save space • Spart Platz • Ahorra espacio - Removable legs without tools • Abnehmbare Füße ohne Werkzeug • Patas desmontables sin herramientas - Quick installation and release • schnelle Montage und Demontage • Instalación y desmontaje rápidos - Stable • Stabil • Estable - All tube ends with caps • Alle Rohrenden mit Kapfen • Todos los extremos de los tubos con tapas.

Tréteau Helsinki

NOIR | U.C. x 4 | x 2 | **300 kg Maxi** | 2,87 kg net
pour 2 tréteaux

- Matériau : métal
- Réglable en hauteur
- Pieds démontables avec rangement intégré dans le cadre du tréteau

Removable legs with integrated storage in the trestle frame • Abnehmbare Beine mit integriertem Stauraum im Bockrahmen • Patas desmontables con almacenamiento integrado en el marco del caballete

↑ 78 - 108 cm ← 75 cm ↗ 50 cm

↓ ?? cm ← 75 cm ↗ 2,5 cm



- ✓ Transport et rangement facilités
- ✓ Gain de place
- ✓ Pieds démontables sans outil
- ✓ Réglable en hauteur
- ✓ Installation et démontage rapides
- ✓ Stabilité
- ✓ Extrémités tubulaires bouchées

Easy transport and storage • Einfache Transport und Lagerung • Transporte y almacenamiento fáciles - Save space • Spart Platz • Ahorra espacio - Removable legs without tools • Abnehmbare Füße ohne Werkzeug • Patas desmontables sin herramientas - Adjustable height • Höhenverstellbar • Altura ajustable - Quick installation and release • schnelle Montage und Demontage • Instalación y desmontaje rápidos - Stable • Stabil • Estable - All tube ends with caps • Alle Rohrenden mit Kapfen • Todos los extremos de los tubos con tapas.



Déplié Unfolded
Aufgeklappt • Abierto



Plié Folded
Gefaltet • Plegado



Tréteau Classic +



Ref Pdt 640021 3



- ✓ Excellent rapport qualité/prix
- ✓ Système de compas innovant pour une sécurité accrue
- ✓ Qualité renforcée : épaisseur du compas et diamètre du tube
- ✓ Pliable pour être peu encombrant

Excellent price / quality ratio • Sehr gutes Preis / Leistungsverhältnis • Excelente relación calidad / precio. Compass system for added security • Compass-System für zusätzliche Sicherheit • Sistema de compas para mayor seguridad - Enhanced-Quality: hinge thickness and tube diameter • Verbesserte Qualität: Scharnierdicke und Rohrdurchmesser • Calidad mejorada: espesor de la bisagra y diámetro del tubo - Foldable therefore takes up little space • Faltbar nimmt daher wenig Platz • Plegable, por lo tanto ocupa poco espacio.

Artisan Galva



- Matériau : acier galvanisé
 - Réglable en hauteur
- Adjustable height • Höhenverstellbar
Altura ajustable

Ref Pdt 640024 4



80/130 cm



- ✓ De type pro/apptitude chantier
- ✓ Robuste
- ✓ Pliable pour être peu encombrant

Professional type. For construction sites • Profi-Ausführung. Für Baustellen • Tipo profesional. Para obras de construcción - Robust and durable • Robust und langlebig • Robusto y duradero - Foldable therefore takes up little space • Faltbar nimmt daher wenig Platz • Plegable, por lo tanto ocupa poco espacio.

Tréteau plastipro *



- Matériau : plastique
- Pieds pliables
- Tampons antidérapants
- Compas : 4 cm

Plastic • Kunststoff • Plástico

Ref Pdt 640026 8



- ✓ Ultra simple et rapide à monter
- ✓ Facile à plier, à transporter et à ranger
- ✓ De type pro/apptitude chantier
- ✓ Supporte une forte charge
- ✓ Robuste et durable
- ✓ Concept novateur ouvrant la gamme à de nouveaux matériaux

Very simple and quick assembly • Sehr einfache und schnelle Montage • Muy sencilla y rápido de montar - Easy to fold, carry and store • Leicht zu falten, zu transportieren und zu speichern • Fácil de plegar, de transportar y almacenar - Professional type. For construction sites • Profi-Ausführung. Für Baustellen • Tipo profesional. Para obras de construcción - Carries a heavy load • Trägt eine schwere Last • Soporta una carga pesada - Robust and durable • Robust und langlebig • Robusto y duradero - Innovative concept. Opens the range to new materials • Innovatives Konzept. Bietet der Kollektion neue Materialien an • Concepto innovador. Abre la gama a nuevos materiales.

Tréteaux Hévéa

Rubberwood Trestle • Hevea-Holzbock
Hevea hout schraag



H.	80 mm	75 mm	80 mm
l.	50 mm	75 mm	80 mm
u.c.	x 27	x 32	x 33

	Ref Pdt		
Taurus (section 20 x 45 mm)	640001 5	-	640000 8
First (section 20 x 35 mm)	-	640020 6	-



* Jusqu'à épuisement du stock





ACCESSOIRES & OUTILLAGE

Fermetures extensibles pour animaux



Fermetures bois extensibles pour animaux

Extensible wood gates for animals
Ausziehbar-holzgitter Holz für Tieren
Cierres extensibles madera para animales



u.c. x 5



Inadaptées aux enfants

Not adapted to children • Passt nicht für Kindern
No aptos para niños

Stop'fix
Pivotante

Pivoting
Holzgitter
Pivotante

Stop'Max
Pivotante

Pivoting
Holzgitter
Pivotante

Press'fix
À pression

Pressure
Drückgitter
A presión

H.	83 cm		
l.	60 / 110 cm	60 / 230 cm	65 / 107 cm

Décor	Ref Pdt		
Blanc White • Weiss • Blanco	742001 2	-	-
Bois Wood • Holz • Madera	742000 5	742011 1	742004 3



Stop'fix



Stop'Max



Press'fix

Mini box fermetures animaux

Mini Box display
for animal
gates

Mini
Box für
Tiergitter

Mini Box
de vallas
para
animales

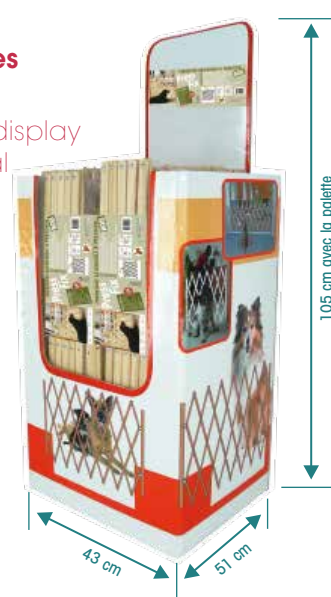

BIEN
VU

	Stop'fix	Stop'Max	Press'fix
UNIT	x 40	x 25	x 30
Décor	Ref Pdt		
Blanc White • weiss • blanco	940093 7	-	-
Bois Wood • Holz • Madera	940092 0	940094 4	940091 3



SÉCURITÉ

Barrières de sécurité enfants

Barrières de sécurité enfants pivotantes

Pivoting children safety gates • Schwenkbare kindersicherheitsgittern
• Pivotante vallas de seguridad para niños



Bois
Wood
Holz
Madera

Pivotante



● Métal Metal • Metall

Fixation avec perçage

With drilling • Zum Schrauben • Con perforación

Vogue

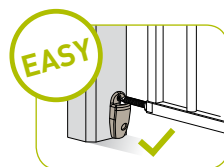
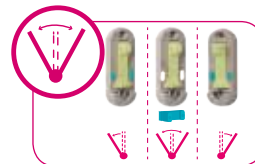
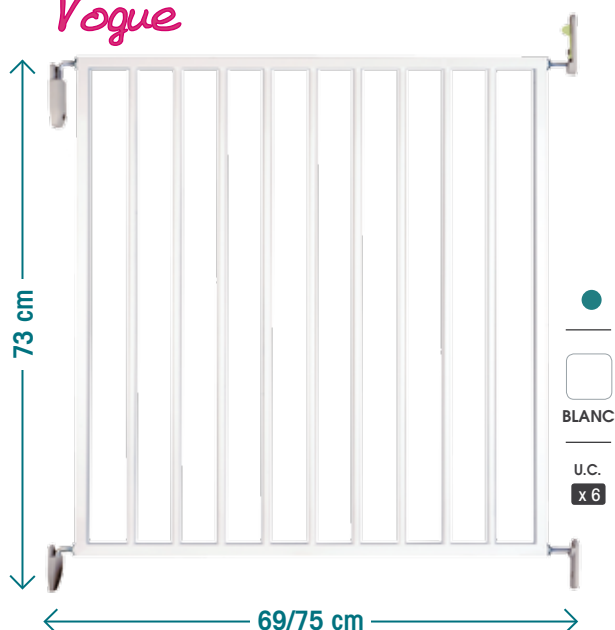

Ref Pdt	742029 6
Kit quincaillerie Hardware ki • Kleineisenwaren • Kit fijaciones	630061 2



Nordlinger Pro vous présente sa nouvelle gamme barrières de sécurité enfants



SÉCURITÉ

Barrières de sécurité enfants

Victoria

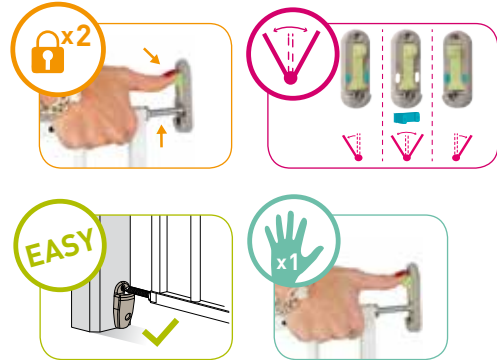
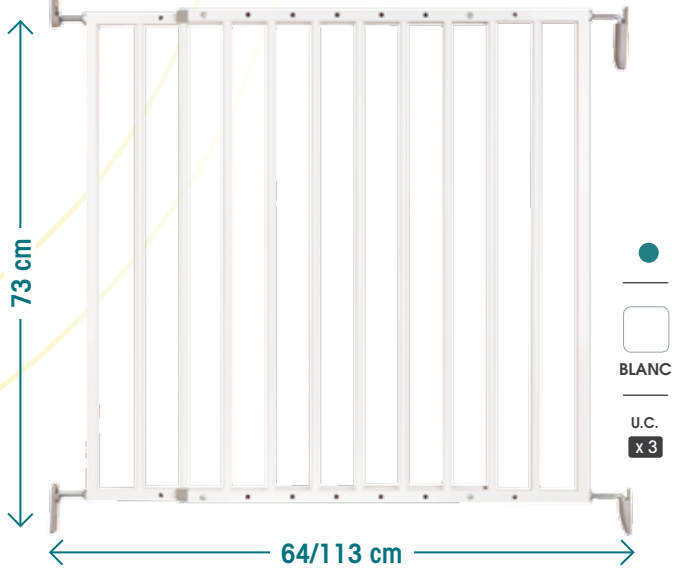

Ref Pdt	742028 9
Kit quincaillerie Hardware ki • Kleineisenwaren • Kit fijaciones	630060 5

Prune

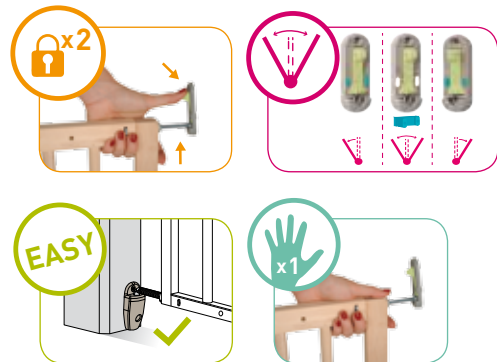
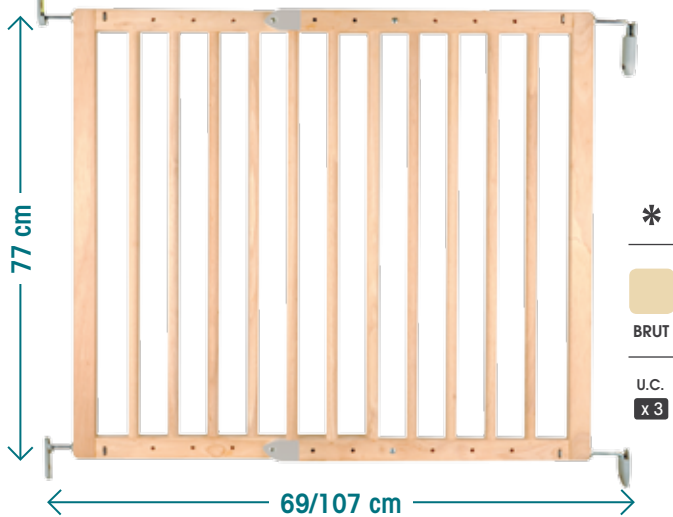

Ref Pdt	742030 2
Kit quincaillerie Hardware ki • Kleineisenwaren • Kit fijaciones	630062 9

Victor

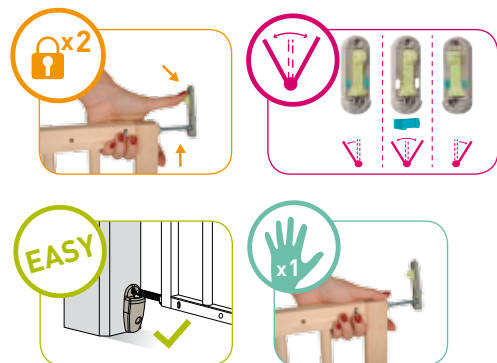

Ref Pdt	742032 6
Kit quincaillerie Hardware ki • Kleineisenwaren • Kit fijaciones	630062 9



SÉCURITÉ

Barrières de sécurité enfants

Barrières de sécurité enfants amovibles

Pull & hold children safety gates

Ziehen & halten kindersicherheitsgittern

Elevar & quitar vallas de seguridad para niños



Bois
Wood
Holz
Madera

Amovible



À pression

Pressure mounted • Zum Drücken • Presión

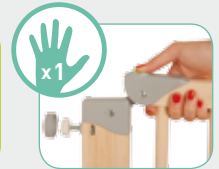
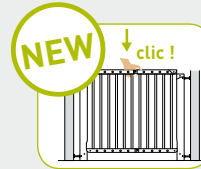
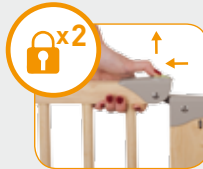

Lila



Ref Pdt	630053 7
Kit quincaillerie Hardware ki • Kleisenwaren • Kit fijaciones	630064 3



Oléane 7



Ref Pdt	630049 0
Kit quincaillerie Hardware ki • Kleisenwaren • Kit fijaciones	630063 6

Oléane 8



Ref Pdt	630050 6
Kit quincaillerie Hardware ki • Kleisenwaren • Kit fijaciones	630063 6



SÉCURITÉ
Barrières de sécurité enfants

Barrières de sécurité enfants portillons

Central Gate children safety gates • Zentrale Tür kindersicherheitsgittern • Puerta Central vallas de seguridad para niños



● **Métal**
 Metal
 Metall

À pression

Pressure mounted • Zum Drücken • Presión



Aalto



BLANC
 U.C. x 3

Ref Pdt	630045 2
Kit quincaillerie Hardware ki • Kleisenwaren • Kit fijaciones	630052 0
Extension blanc Extensions • Erweiterung • Extension	Extension A 8 cm 630046 9 Extension B 16 cm 630047 6 Extension C 20 cm 630048 3

India



BLANC
 U.C. x 3

Ref Pdt	630057 5
Kit quincaillerie Hardware ki • Kleisenwaren • Kit fijaciones	630066 7
Extension blanc Extensions • Erweiterung • Extension	Extension A 8 cm 630046 9 Extension B 16 cm 630047 6 Extension C 20 cm 630048 3

Sofia

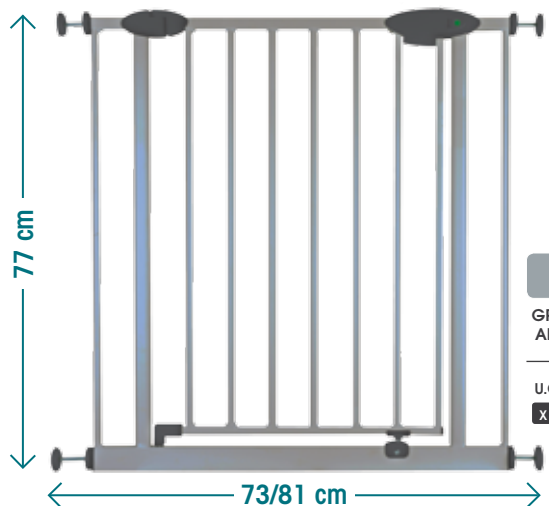

GRIS ALU
 U.C. x 3

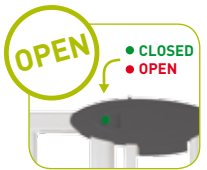
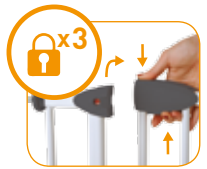

Ref Pdt	630051 3
Kit quincaillerie Hardware ki • Kleisenwaren • Kit fijaciones	630065 0
Extension gris alu Extensions • Erweiterung • Extension	Extension A 8 cm 630054 4 Extension B 16 cm 630055 1 Extension C 20 cm 630056 8

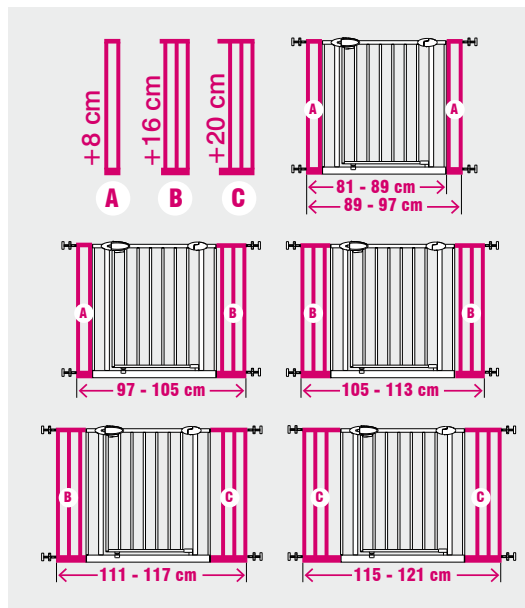



SÉCURITÉ

Barrières de sécurité enfants



Modèles Models Modelle Modelos	Coloris	l. cm	H.* cm	U.C.	Bois Wood Holz Madera	Métal Metal Metall	Ref Pdt	Fixation				
								À pression Pressure mounted Zum Drücken Presión	Avec perçage With drilling Zum Schrauben Con perforación	Pivotante Pivoting Schwenkbare Pivotante	Portillon central Central Gate Zentrale Tür Puerta Central	Amovible Pull & hold Ziehen & halten Elevar & quitar
Victoria	Blanc • White • Weiss • blanco	64/113	73	x 3	-	●	742028 9	-	●	●	-	-
Vogue	Blanc • White • Weiss • blanco	69/75	73	x 6	-	●	742029 6	-	●	●	-	-
Prune	Brut • Raw • Roh • Bruto	69/107	77	x 3	*	-	742030 2	-	●	●	-	-
Victor	Blanc • White • Weiss • blanco	69/107	77	x 3	*	●	742032 6	-	●	●	-	-
	Brut • Raw • Roh • Bruto											
Lila	Brut • Raw • Roh • Bruto	70/103	77	x 5	*	-	630053 7	●	●	-	-	●
Oliane 7	Brut • Raw • Roh • Bruto	70/75	77	x 5	*	-	630049 0	●	●	-	-	●
Oliane 8	Brut • Raw • Roh • Bruto	80/85	77	x 3	*	-	630050 6	●	●	-	-	●
Sofia	Alu • Alu • Alu • Alu	73/81	77	x 3	-	●	630051 3	●	-	-	●	-
Aalto	Blanc • White • Weiss • blanco	73/81	77	x 3	-	●	630045 2	●	-	-	●	-
India	Blanc • White • Weiss • blanco	73/81	77	x 3	-	●	630057 5	●	-	-	●	-

* Hauteur de protection

Barrière pare feu / multifonctions

Fire guard gate • Kaminschutzgitter • Valla cortafuego



H. 75 cm L. 73 - 370 cm



x 6 pans

Ref Pdt 742022 7





SÉCURITÉ
Barrières de sécurité enfants

Pour protéger l'enfant à la maison

To protect children at home
Um die Kindern ins Hause Schützen
Para proteger los niños en la vivienda



	Ref Pdt
1 Cale-porte anti-dérapant Non-slip door wedge Rutschsicherer Türkeil • Calzo puerta antifidelizante	742012 8
2 Loquet souple multi-surfaces Multi surface flexible latch Flexibler Riegel für alle Oberfläche • Pestillo flexible multi-superficies	742015 9
3 Protection coins de table Protection for table corners Schützung für Tafelecken • Protege-esquinas de mesa	742013 5
4 Bloque-porte en mousse Rubber foam door block Türbloeierungssystem • Bloqueo puerta espuma	742014 2

NOUVEAU

Barrière de lit

Bedguard • Bettgitter
Valla de cama

HÉVÉA | H. 40 cm L. 91 cm

| u.c. x 5 |

Ref Pdt 742026 5



Adaptateur pour escalier

To close staircases • Om trappen te sluiten • Para cerrar escaleras

x 2 | u.c. x 5 | |

Ref Pdt 742021 0



Aides à la vente

Sales helps • Verkaufshilfen • Soportes de venta

	UNIT	Ep. x l. x L.	Ref Pdt
1 Cross filaire 6 broches 6 Hooks display unit • 6 Brochen Präsenter Expositor 6 pinchos		20 x 5,5 x 125 cm	940068 5
Cross filaire 6 broches + ILV thermo (skin chant)	x 42		940096 8
Cross filaire 6 broches + ILV adh. (skin chant)	x 48		940097 5
2 Dévidoir vertical G.M. Display X.L. • Präsenter X.L. • Expositor X.L.		20 x 17 x 112 cm	940019 7
Dévidoir vertical G.M. + ILV thermo			940098 2
Dévidoir vertical G.M. + ILV adh.			940099 9
Dévidoir vertical G.M. + ILV mastiplast	x 96		940100 2
3 Broches dévidoir D + G		35 x 10 x 8 cm	940004 3
4 Cross skin fix	x 6	2,1 x 1,5 x 30 cm	970020 4
5 Présentoir 8 broches 8 Hooks display unit 8 Brochen • Expositor 8 pinchos		30 x 42 x 48 cm	940003 6
Présentoir 8 broches + ILV thermo + ILV taquets			940108 8
Présentoir 8 broches + ILV Adh. + ILV Taquets			940109 5
6 Présentoir filaire clips (boîtes clips)	x 22	10 x 22 x 92 cm	970016 2
7 Présentoir filaire lattes (lattes) (embouts)	x 30 x 10		940072 2
Présentoir filaire + ILV profils Alu		20,4 x 15 x 153 cm	940113 2
Présentoir filaire lattes + ILV placflex			940134 7
Présentoir filaire lattes + ILV cannage			940138 5
Présentoir filaire lattes + ILV lattes			940101 9
8 Cross filaire 4 broches Cross filaire 4 broches + ILV taquets (skin taquet)	x 24	20 x 5,5 x 127 cm	940105 7 940106 4
9 Box "clips" : 3mm (250) 3mm (100) autres	x 250 x 500 x 175		940005 0
10 Mini box fermetures animaux (press fix) (stop fix) (stop max)	x 30 x 40 x 25		940071 5
11 Présentoir escalier "barrières"			940110 1
12 Mini box barrière enfants			940070 8



Les stickers

	l. x H.	Ref Pdt
Sticker Placfix		940053 1
Sticker Profplast	17 x 25 cm	940050 0
Sticker Mastiplast		940020 3
Sticker Meladhesiv'		940067 8
Sticker Melafix	17 x 25 cm	940066 1
Sticker Prof'Alu		940028 9
Sticker Placflex		940104 0
Sticker Profil XSC - XSB	17 x 25 cm	940107 1
Sticker Clips		940029 6
	17 x 25 cm	940132 3
Plinthes plastique	9 x 30 cm	940133 0
Sticker Lattes pour filaire		940073 9
Sticker Taquets	17 x 25 cm	940102 6
Sticker Rapid'Fix		940103 3
Olymos 3		940038 8
Concorde 5	30 x 10 cm	940124 8
Opéra 3 73		940125 5
Byblos 4		940126 2
Modulos 3	30 x 10 cm	940044 9
Dolia		940032 6
Tamos		940056 2
Naxos	30 x 10 cm	940127 9
Stop'Max		940079 1
Press'Fix		940080 7
Stop'Fix		940081 4
Placflex	30 x 30 cm	940122 4
ILV pread		940135 4
ILV cannage	17 x 25 cm	940136 1
ILV profil transparent étanchéité plinthes		940137 8

Ref Pdt 940070 8

Mini box barrières de sécurité enfants

Mini box display for baby safety gates • Mini box für kinder sicherheitsgitter • Mini box de vallas de seguridad para niños



	UNIT	Victoria	Vogue	Prune	Victor	Oléane 7	Lila
		x 20	x 35	x 15	x 15	x 20	x 12
Décor		Ref Pdt					
Blanc	White • Weiss • Blanco	940140 8	940142 2	-	-	-	-
Brut	Raw • Roh • Bruto	-	-	940144 6	-	940148 4	940150 7
Blanc & Brut	White • Weiss • Blanco & Raw • Roh • Bruto	-	-	-	940146 0	-	-

Les nuanciers

The colour schemes
Die Farben • Los muestrarios



Les nuanciers	Ep.	Ref Pdt	Les nuanciers	Ref Pdt
Melanor	0,3 mm	940022 7	Alese	940027 2
Nordex	0,8 mm	940023 4	QSapin	940026 5
Chant	2 mm	940024 1	Méla miné grandes largeurs	E005
Bois Rolchant	-	970025 8		



**Consultez le catalogue
où que vous soyez !**

Accédez depuis votre
smartphone ou votre tablette
numérique au catalogue à
feuilleter sur internet.

www.nordlinger-pro.com

contact@nordlinger-pro.com

CS n°20001 Vignolles • 16300 Barbezieux-Saint-Hilaire • France
France tél : 05 45 78 19 99 • fax : 05 45 78 28 80
International tél : 0033 545 787 957 • fax : 0033 545 782 880

N°TVA : FR83 485310262 / RCS Angoulême : 485310262 / SIRET : 48531026200012
© Crédits photos - Fotolia : Photographmd - Ostap25 - Shutterstock - Freepik - Mickaël Tollemer.
Conception © Maia www.maia-creation.com